

Montageanleitung Mounting instruction

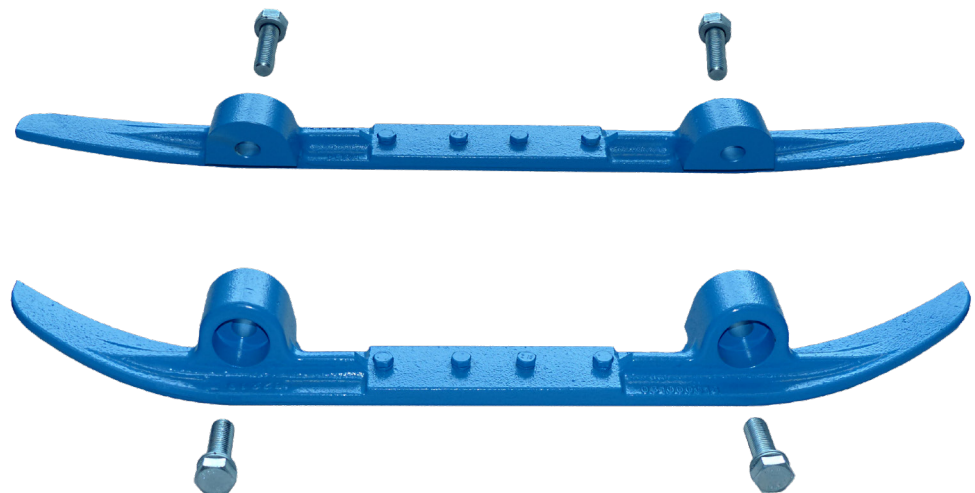

Verbreiterung CR 3

0196631
0196632

Position Ref.No.	Menge Quantity	Bezeichnung / Description		Hinweis Hints
1	2	Anbauplatte	Extension plate	
2	4	Sicherungsscheibe	Lock washer	Nord-Lock 16,0
3	4	Sechskantschraube	Hexagon screw	DIN933-M16x50-10.9

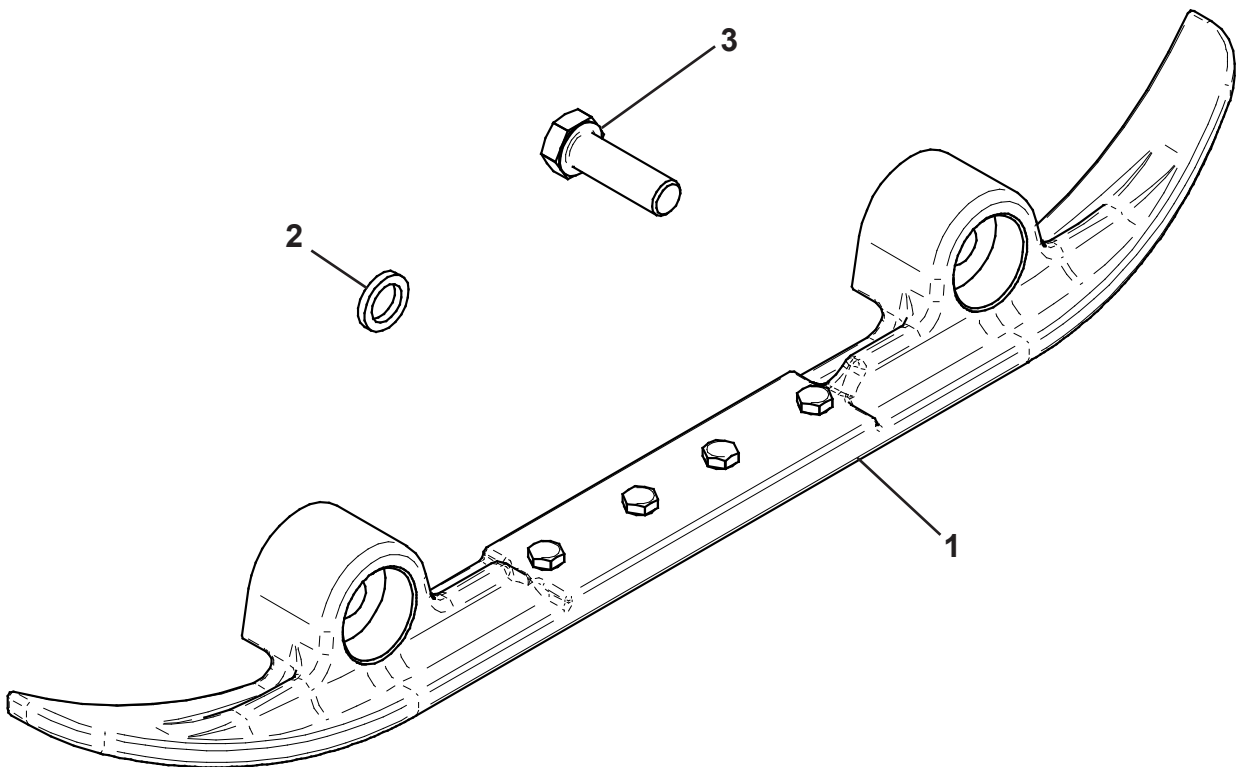

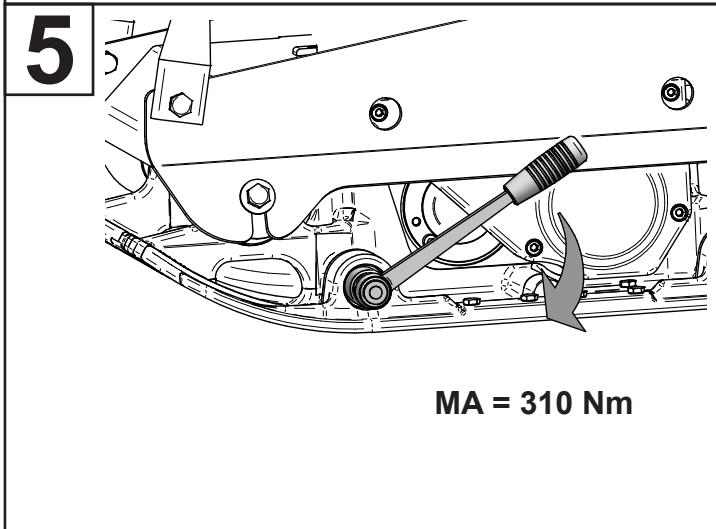
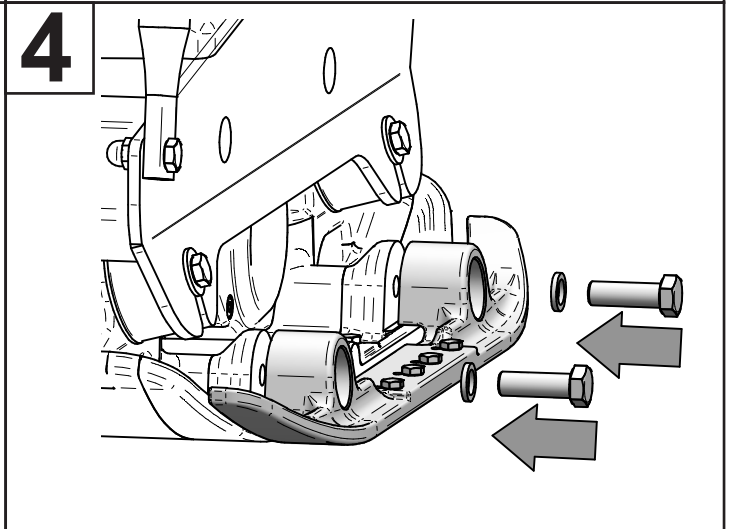
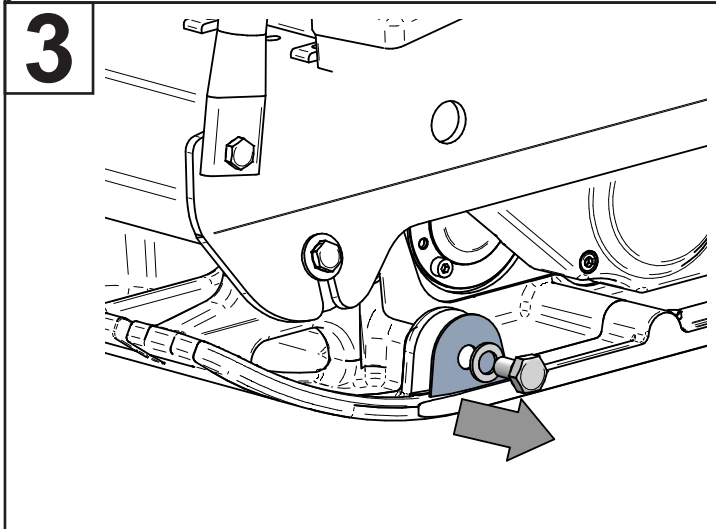
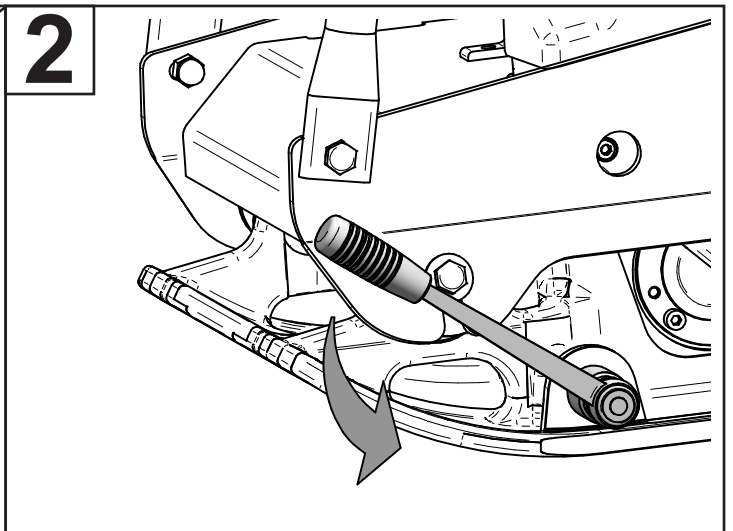
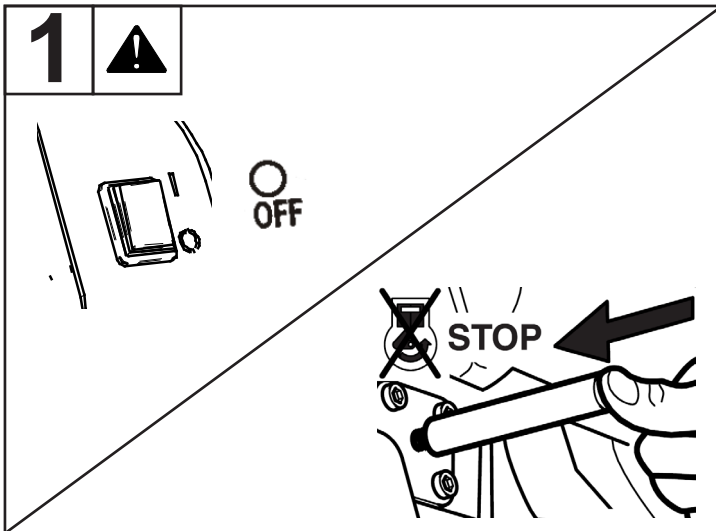



facebook.com/WeberMT



youtube.com/MyWeberMT



Weber Maschinenteknik GmbH

Im Boden 5-8, 10 · 57334 Bad Laasphe · Germany
Phone +49 2754 398 0 · Fax +49 2754 398 101
info@webermt.de · www.webermt.de