

Operating and Maintenance Manual



CR 1

CR 2

Robin-Subaru EX 17

Item no. 000115502

Item no. 000115505

Item no. 000115602



Weber Maschinentechnik GmbH

Im Boden 5 - 8, 10

57334 Bad Laasphe-Rückershausen / Germany

Telephone +49 (0) 27 54 / 398-0

Fax +49 (0) 27 54 / 398-101

E-Mail: info@webermt.de

Web: www.webermt.de

Table of contents

Introduction	4
Safety guidelines	5
Graphic presentation	9
Device description	10
Technical data	11
Activities prior to starting work	13
Starting	15
Compacting	16
Shutting down	16
Maintenance overview	17
Maintenance work	18
Operating fluids and fill levels	20
Troubleshooting	20
Storage	21
Contact addresses	23

Introduction

This operating and maintenance manual is designed to facilitate familiarization with your soil compactor, and to enable you to maintain the compactor and use it for its intended purpose. When complying with the instructions in the operating and maintenance manual you help avoid hazards, reduce repair and downtime costs, and increase the reliability and service life of your compactor.

This operating and maintenance manual must always be available at the implementation site of the soil compactor.

If necessary you can obtain additional information from your authorized WEBER dealer, or you can obtain information from one of the contact addresses on the last page.

You can obtain information on the assembled Robin-Subaru gasoline engine and find a spare-part list for it at **www.robin-europe.de**

The valid conformity declaration is enclosed with every machine delivery.

Safety guidelines

General

All safety instructions must be read and complied with, non-compliance results in

- danger to life and limb of the user
- impairments to the machine or other property.

In addition to the operating manual, the accident-prevention regulations in the country where the appliance is used must be complied with.

Intended use

The soil compactor should only be used if it is in a technically faultless condition, as intended, in a safety-conscious and hazard-conscious manner, in compliance with the instructions in the operating manual. Malfunctions that impair safety must be eliminated without delay.

The CR 1/CR 2 soil compactor is designed exclusively for compacting

- sand
- gravel
- crushed rock
- semi-cohesive mixed material
- concrete paving stone
- asphalt.

Any other use of the soil compactor is considered to be improper use for which the owner shall be exclusively responsible. All liability is rejected if damage occurs due to non-compliance with this provision. This risk is borne solely by the user.

Easily foreseeable misuse

Any use for which the machine is not intended.

Operation

Soil compactors are only permitted to be operated by suitable persons of or above the age of eighteen. Personnel must be instructed in how to guide the compactor by the owner or by the owner's assigned personnel.

The machine operator must comply with traffic regulations. If instructions that affect safety are given by third parties, then the operator must be authorized to reject these instructions.



Unauthorized persons are forbidden from being in the area of the soil compactor during the compacting process.

Protective equipment

This machine is capable of exceeding the permissible sound level of 80 dB(A). The owner might also face additional dangers when using the machine. Precautionary action must, therefore, be taken.

Protective equipment includes:



hearing protection



hard hat



safety shoes



protective gloves

Operation

Prior to starting work the owner of the compactor must be familiar with the work environment. The work environment includes obstacles in the work and traffic area, the bearing capacity of the ground, as well as the necessary safeguarding of the construction site in the area adjacent to public traffic; and it includes compliance with traffic regulations.

The soil compactor should only be operated when the protective fixtures are mounted. The protective fixtures must all be in functional condition.

At least once per shift the compactor must be checked for apparent defects. If there are apparent defects then operation of the compactor must be stopped immediately, and the responsible person must be informed. Prior to restarting, compactor malfunctions that have occurred must be corrected.

Always maintain adequate clearance to the edges of pits and embankments.

Do not drive at ninety degrees to slopes to prevent the compactor from tipping over.

After work has been concluded secure the compactor in accordance with statutory regulations, particularly in the area of public traffic surfaces.

Operation under difficult conditions

 Never inhale the exhaust gas; it contains carbon monoxide, a colorless and odorless gas that is extremely hazardous, which, if inhaled even briefly, can cause unconsciousness and death.

Therefore, never operate the engines in enclosed areas or in areas that are poorly ventilated (tunnels, caves, covered pits, etc.).

Exercise particular caution when operating the engine in the vicinity of people and livestock.

 The soil compactor described in this operating manual is suitable for use in trenches that are deeper than shoulder height, provided the following basic conditions have been met:

- trench width at least 1.5 m
- trench depth no more than 3.0 m
- open trench width at least 10 m
- slight wind movement in the trench
- compactor is used for periods of no more than 4 x 15 minutes per shift, interrupted by breaks (each lasting approx. 1 hour)

If these basic conditions are not satisfied, the owner is required to implement the protective measures identified as necessary to avoid CO poisoning during his own risk assessment. These may include:

- use of zero-emission compacting equipment
- blower-supported ventilation with a fan forcing air along the length of trench

The use of respiratory equipment during operation of this gasoline-powered compactor without documented evidence of conformity and without the necessary precautions **is generally prohibited!**

- as CO will accumulate in the blood after repeated use
- as CO filters have a short service life

Maintenance and repair work

Only use **original Weber spare parts** to ensure reliable and safe operation for maintenance or repair work.

Hydraulic hose lines must be checked at regular intervals in accordance with standard engineering practice, or they must be replaced at appropriate intervals, even if no signs of safety-relevant defects are present.

Adjusting tasks, maintenance tasks, and inspection tasks must be carried out on schedule as specified in this operating and maintenance manual. These activities should only be executed by instructed personnel.

For repair, service, or inspection work the engine of the compactor must be safeguarded against unintentional starting.

All pressurized lines, particularly hydraulic lines and lines of the injection system of the drive motor must be depressurized before performing maintenance or repair tasks.

For maintenance and repair tasks the compactor must be parked on a level and stable substrate and must be secured from rolling off or tipping over.

Heavy components and assemblies must be secured to and lifted by hoisting machines that can bear their weight when they are replaced. Ensure that no hazard is caused by raising components or assemblies.

Do not position yourself or work under suspended loads.

 If lubricating oils and fuel come into contact with skin, they can cause skin cancer. Upon contact with the skin, clean affected skin with suitable cleaning agent without delay.

Inspection

Compactors must be inspected in accordance with the corresponding implementation conditions and operating conditions, as needed; however an inspection to ensure operationally safe status must be performed by an expert at least once a year. The results of the inspection must be recorded in writing and must be stored at least until the next inspection.

Cleaning work

Prior to cleaning the compactor with a high-pressure cleaner, protect all accessible energized switches, cable connections, etc. against water penetration by masking them off.

Cleaning tasks should only be executed in areas that are suitable and have been approved for this purpose (oil separator amongst others).

Disposal

All operating fluids and auxiliary materials must be disposed of in an environmentally-compatible manner in accordance with country-specific regulations.

Important information for operating and maintenance personnel is marked by pictograms.



Warning against irritants or materials hazardous to health



Warning against a hazardous place



Warning against a suspended load



Wear ear protection



General regulation



Environmental protection



Hard hat



Safety shoes



Protective gloves

Graphic presentation

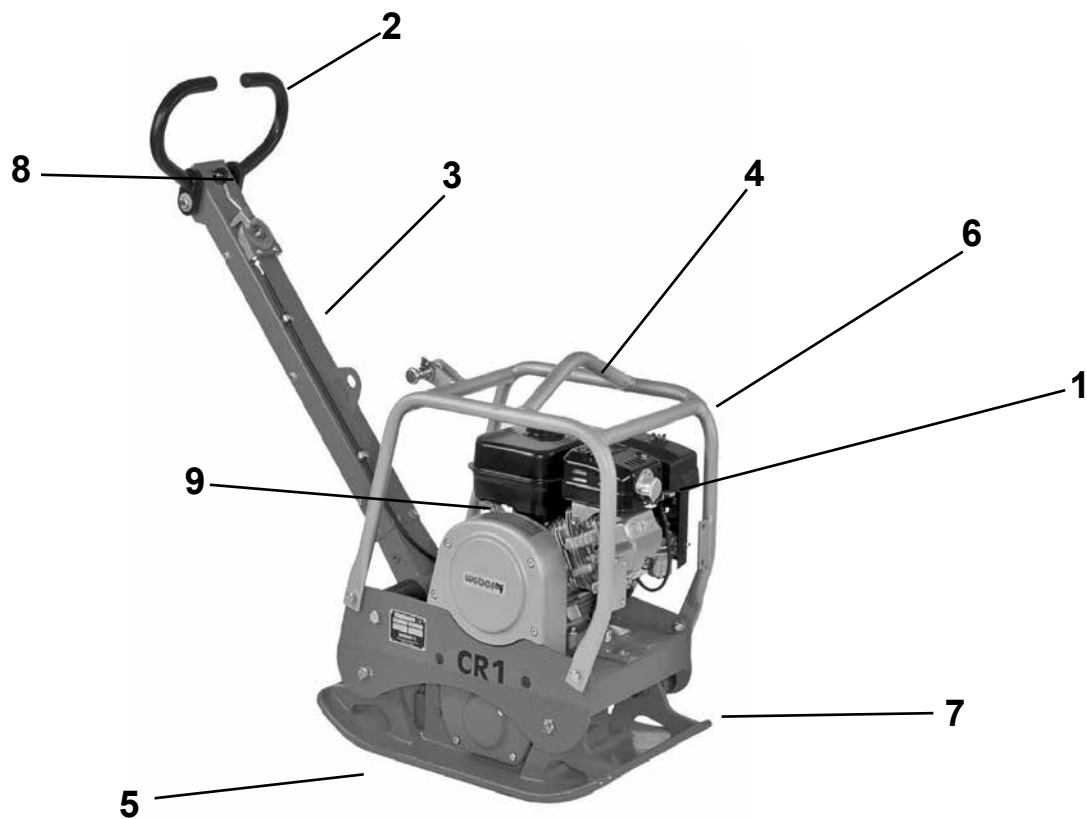

Overall view CR 1

- 1 Engine
- 2 Drive lever
- 3 Manual guidance rod
- 4 Lifting ring
- 5 Base plate
- 6 Protective frame
- 7 Exciter
- 8 Gas lever
- 9 Hearing protection (sticker)



Device description

The CR 1/CR2 compactor is used for road building and landscaping compaction tasks.

Drive

The machine is propelled by an air-cooled Robin-Subaru gasoline engine.

Force is transferred to the exciter mechanically via a V-belt.

Operation

The Robin-Subaru gasoline engine is started by means of a manual starting device.

After starting, vibration is switched on via the centrifugal clutch attached to the engine. Use the gas lever to vary the engine speed between idle and full throttle.

Forward and reverse is variably controlled via the handle attached to the manual guidance rod.

Technical data

	CR 1 R	CR 2 R
Weight		
Operating weight CECE in kg (basic device)	104	132
Dimensions		
Overall length (in mm)	1044	1079
Overall width (in mm)	400	450
Height with folded manual guidance rod (in mm)	1006	1061
Base plate length (base in mm)	300	320
Pressure surface (in mm)	400x300	450x320
Drive		
Engine manufacturer	Robin-Subaru	Robin-Subaru
Type	EX 17	EX 17
Performance at operating speed in accordance with ISO 3046-1 (kW)	4.2	4.2
Combustion process	4-stroke gasoline	4-stroke gasoline
Operating speed (1/min)	3350	3350
Operating speed (ground-dependent in m/min)	20	14
Incline capacity (ground-dependent in %)	30	30
Area capacity (in m ² /h)	480	378
Vibration		
System	Two-wave vibrator	Two-wave vibrator
Drive concept	Mechanical	Mechanical
Frequency (in Hz)	100	100
Centrifugal force (in kN)	20	25

	CR 1 R	CR 2 R
Noise emissions in accordance with 2000/14/EC		
Sound pressure level L_{PA} ascertained in accordance with EN 500, in dB (A)	100	100
Sound power level L_{WA} ascertained in accordance with EN ISO 3744 and EN 500, in dB (A)	108	108
Vibration values		
Root-mean-square acceleration value for hand-arm vibration ascertained in accordance with EN 500 in m/s ²	4,7	5,6
 In accordance with directive 2006/42/EC, complying with the vibration values is the owner's responsibility.		

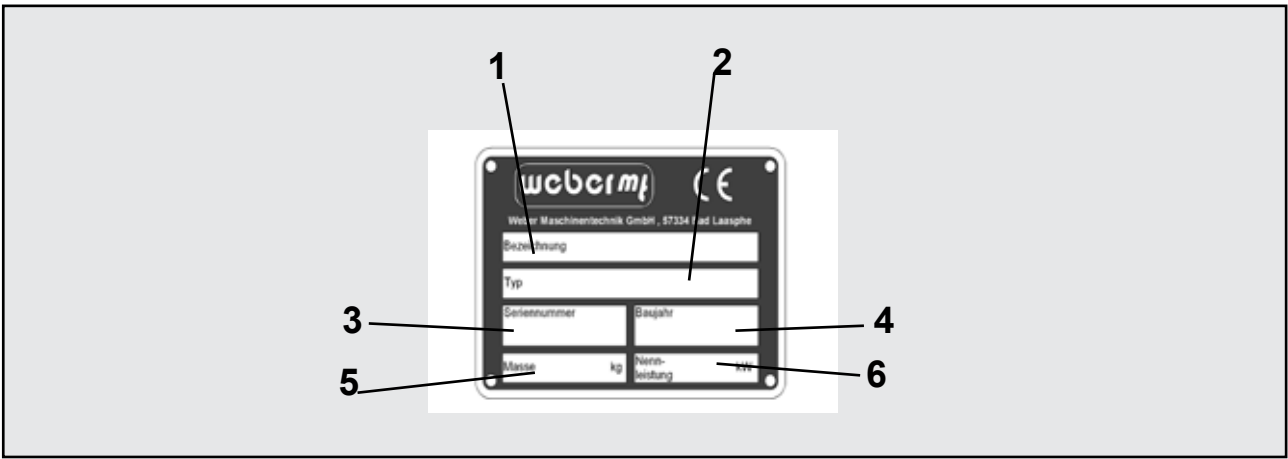

1 Description

.....

3 Serial number

.....

5 Mass

.....

2 TYPE

.....

4 Year of construction

.....

6 Rated power kW

.....

Activities prior to starting work

Transport

 When transporting the soil compactor on a vehicle, secure it with suitable restraints.

Arrest the manual guidance rod (1) with the spring bolt (2).

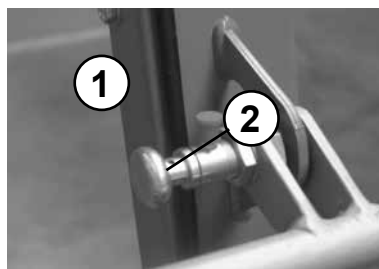

Fit the crane hook into the protective frame (1) and lift the machine onto the means of transport selected.

 Only use lifting machines with a minimum bearing capacity of 200 kg.

 Do not step under suspended loads.

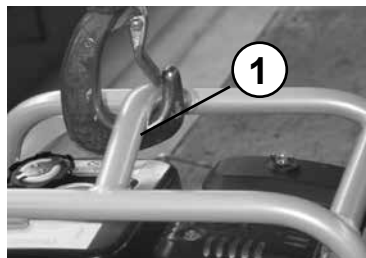

Checking the engine oil level

Pull the oil dip stick (1) out of the crankcase.

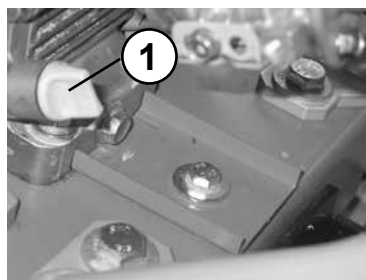

The correct oil level is between the min. and max. marks.

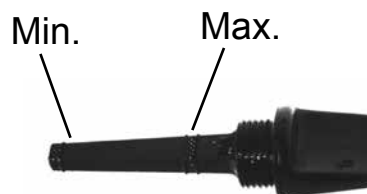

Check the fuel level

Open and remove the gas cap (1), check the level, if necessary top off to the lower edge of the filler neck with clean fuel in accordance with the specification.

 For work at the fuel system, have a suitable fire-extinguishing agent at the ready.



 Fire, naked light, and smoking is forbidden!

Installing the protective mat

Fasten the protective mat with holder, screws, spring-lock washers and nuts on the base plate front and rear.

 Ensure that the protective mat rests under the base plate.



Transport with hand truck

Arrest the manual guidance rod (1) with the spring bolt (2).

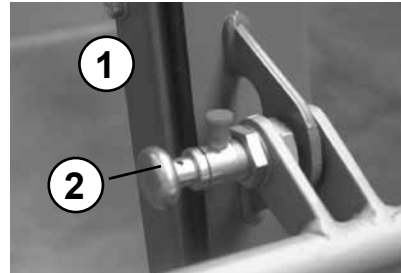

Mount the retaining pin (1).

Slide the hand truck (2) under the base plate.

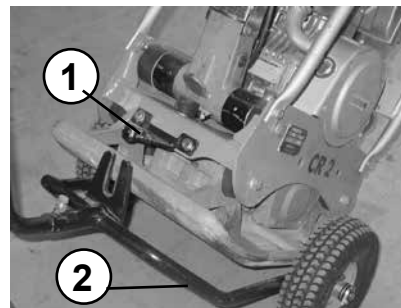

Engage the retaining pin (1) in the retaining element (2) of the undercarriage.

 The retaining pin must be correctly engaged in the retaining element, otherwise there is danger of injury due to the compactor sliding off.

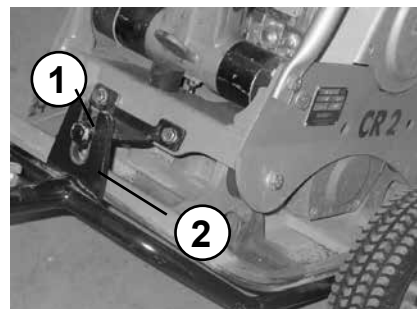

Mounting the water sprinkling system

Use the screws (2) on both sides and the star-knob screw (3) to fasten the water tank (1).

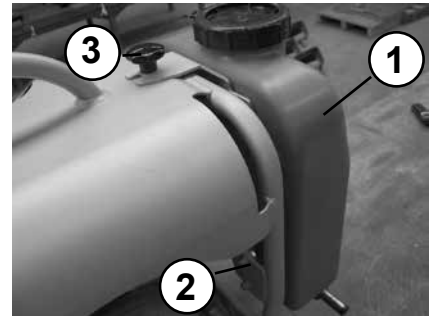

Starting

Turn the short-circuit button (1) to the "ON" position.

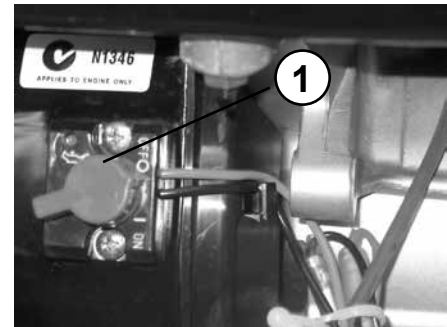

Bring the gas lever (1) into full-throttle position.

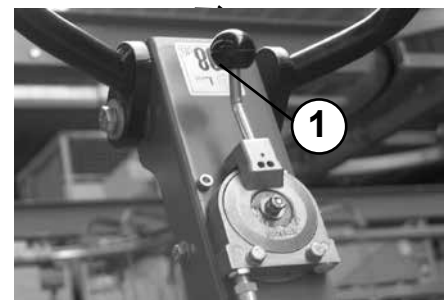

Slide the choke lever (1) to the left (close).
Open the fuel cock (2).

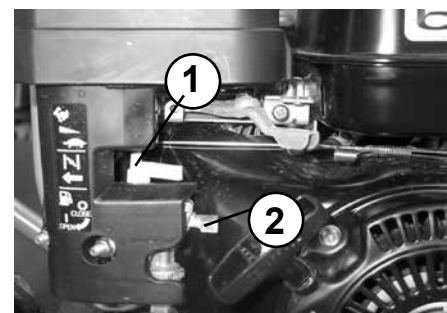

Slowly tighten the handle (1) of the reversing starter (2) until resistance is noticeable.
Allow the handle (1) to glide back into the initial position, and then forcefully and completely pull it through with both hands.

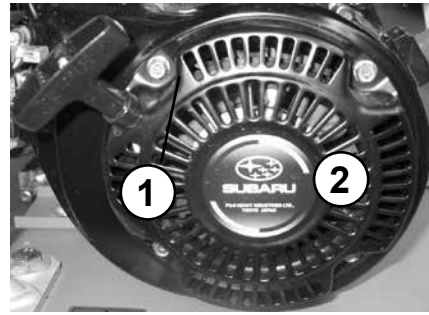

 After the engine has warmed up, slide the choke lever to the right (open).

Compacting

Bring the gas lever (1) into full-throttle position.

Control drive speed and direction of travel with the handle (2).

 Only run machine within reach of the manual guidance rod.

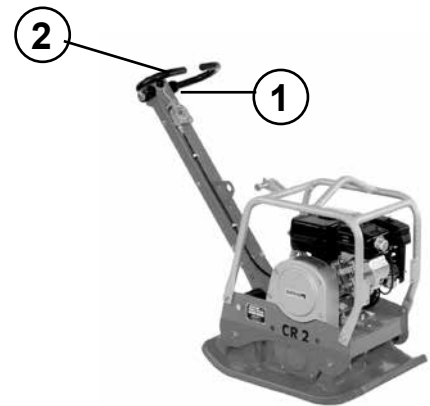

Shutting down

Bring the gas lever into idle position.

Close the fuel cock (1).

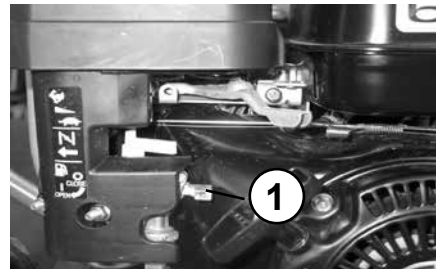

Turn the short-circuit button (1) to the “0” – OFF position.

 Completely empty the water tank if there might be a frost.





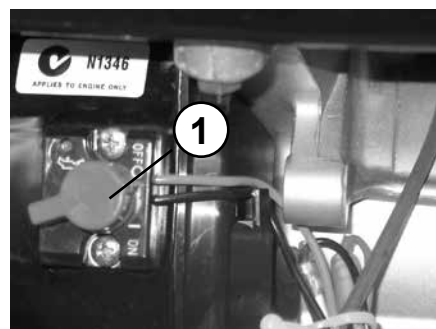

 During breaks – even if they are short – the machine must be shut down.

 Parked devices that represent an obstacle must be safeguarded against through conspicuous measures.



Maintenance overview

Maintenance interval	Maintenance point	Maintenance activity
After the first 10 operating hours	Engine	<ul style="list-style-type: none"> – Change the engine oil – Re-tighten all accessible threaded connections
Every 8 operating hours/daily	Air filter	<ul style="list-style-type: none"> – Clean air filter insert, check for damage, replace if necessary
Every 50 operating hours/every 6 months	Engine	<ul style="list-style-type: none"> – Change the engine oil – Change the fuel oil
Every 150 operating hours/every year	Transmission Exciter	<ul style="list-style-type: none"> – Change oil – Change oil

-  The regulations of the engine manufacturer must be complied with in addition to the above maintenance overview!
-  Work must be carried out using regulation tools, and the operating and maintenance manual must be complied with for all work.
-  All maintenance work: Select a collection vessel that is large enough to prevent oil from spilling onto the ground. Dispose of waste oil in an environmentally friendly manner (regulation on waste oils).
-  Dispose of oils, greases, cloths soaked in oil, and replaced parts with oil on them in an environmentally friendly manner.
-  If lubricating oils and fuel come into contact with skin, they can cause skin cancer. Upon contact with the skin, clean affected skin with suitable cleaning agent without delay.
-  If accessible during maintenance, check the condition and stability of all screws.

Maintenance work

Change the engine oil

Remove the water tank (1).





Unscrew dip stick (1).

Remove the oil drain screw (2) and drain oil completely.

 Only drain engine oil when at operating temperature.

Screw the oil drain screw back in and fill the engine with oil as specified.

 Danger of scalding due to hot oil.

 When working in the area of the engine compartment there is a danger of being burnt!

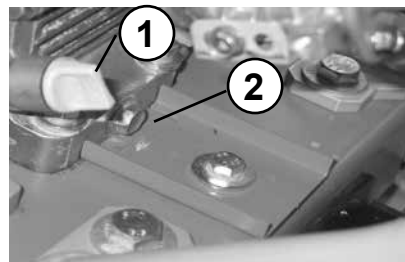



Clean/change air filter cartridge

Unscrew the air filter cover (1).



Remove the air filter insert (1) from the air filter enclosure. Clean the air filter insert in accordance with the guidelines provided by the engine manufacturer, replace in the case of damage or extreme fouling.

 Dispose of oils, greases, cloths soaked in oil, and replaced parts with oil on them in an environmentally friendly manner.

 If lubricating oils and fuel come into contact with skin, they can cause skin cancer. Upon contact with the skin, clean affected skin with suitable cleaning agent without delay.



Changing the oil in the exciter

Remove the oil drain screw (1) and drain oil.

To fill – tilt the machine slightly and fill with fresh oil through the drain opening in accordance with the fill level table.

 Select a collection vessel that is large enough to prevent oil from spilling on the ground. Dispose of waste oil in an environmentally friendly manner (regulation on waste oils).

 Wipe up/off oil slick and oil residue and dispose of fuel-soaked cleaning cloths in an environmentally responsible manner.

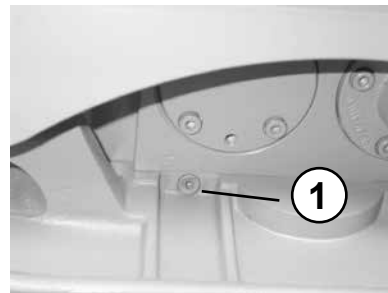

Checking the V-belt

Remove the V-belt guard (1).

Check the V-belt (1) for cracks, damaged flanks, and wear. If there is excessive wear – replace the V-belt as specified in the repair manual.

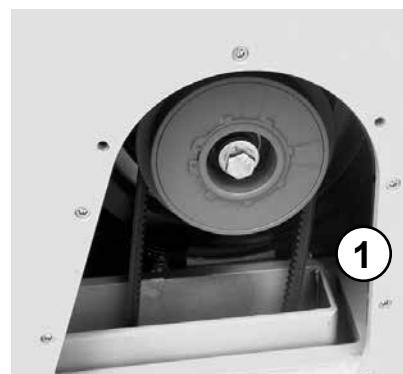

Operating fluids and fill levels

Assembly	Operating material Summer Winter Quality	Quantity	Quantity
		CR 1 R	CR 2 R
Engine Engine oil	SAE 10 W 40 (-10 ~ +50 °C) API – CD CE-CF-CG or SHPD or CCMC – D4 – D5 – PD2	0.6 l	0.6 l
Fuel tank	Unleaded gasoline	3.6 l	3.6 l
Vibrator	Fully-synthetic transmission fluid API GL-5/GL-4 First filling Fuchs Titan SINTOPOID LS SAE 75W-90	0.5 l	0.5 l
Water tank			14 l
Transmission	Transmission fluid DEXRON II-D-ATF First filling Fuchs Titan ATF 3000 or equivalent	As necessary	As necessary

Troubleshooting

Fault	Possible cause	Remedy
Soil compactor does not start	Operating error	Execute start process as prescribed
	Lack of fuel	Check the fuel level
	Fuel filter fouled	Change the fuel filter
	Air filter fouled	Clean/change air filter cartridge
No vibration/ no forward motion or insufficient forward motion	Vibrator V-belt defective	Change vibrator V-belt
Soil compactor does not switch	Wrong hydraulic oil level in the manual guidance rod	Check oil level Correct oil level

Actions to be taken before long-term storage (longer than a month)

Entire soil compactor	<ul style="list-style-type: none">– Clean thoroughly– Check for leaks– If there are leaks, correct defects
Fuel tank	<ul style="list-style-type: none">– Empty fuel and fill with clean fuel up to the lower edge of filler neck
Engine	<ul style="list-style-type: none">– Check oil level, if necessary fill to upper oil-level mark– Check air filter, clean, replace if necessary– Check fuel filter, change if necessary
All bare parts / accelerator / accelerator control cable / fastening bolts	<ul style="list-style-type: none">– Oil / grease



If the machine is to be stored for longer than six months, then contact the Weber service organization to discuss additional measures.



Weber Maschinentechnik GmbH

For problems, questions and further information refer to one of the following addresses:			
in Germany	WEBER Maschinentechnik GmbH Im Boden 5 – 8, 10 57329 Bad Laasphe - Rückershausen	Telefon Telefax E-Mail	+ 49 (0) 2754 - 398-0 + 49 (0) 2754 - 398101-switchboard + 49 (0) 2754 - 398102- spare parts- directlinie g.voelkel@webermt.de
in France	WEBER Technologie SARL 14' rue d' Arsonval 69680 Chassieu	Telefon Telefax E-Mail	+ 33 (0) 472 -791020 + 33 (0) 472 -791021 france@webermt.com
in Poland	WEBER Maschinentechnik Sp. zo.o. Ul. Jeziorki 86 02-863 Warszawa	Telefon Telefax E-Mail	+ 48 (0) 22 - 739 70 - 80 + 48 (0) 22 - 739 70 - 81 + 48 (0) 22 - 739 70 – 82 info@webermt.com.pl
In Tschechien	WEBER MT s.r.o. V Piskovne 2054 278 01 Kralupy nad Vitavou	Telefon E-Mail	+ 42 (0) 776 222 216 + 42 (0) 776 222 261 info@webermt.cz
in USA and Canada	WEBER MT, Inc. 45 Dowd Road Bangor, ME 04401	Telefon Telefax E-Mail	+ 1(207) - 947 - 4990 + 1(207) - 947 – 5452 sales@webermt.us service@webermt.us
in South - America	WEBER Maschinentechnik do Brasil Rua João Werno Erhart, 4691 Bairro Rincão 93310-405 Novo Hamburgo /RS Brasil	Telefon Telefax E-Mail	+ 55 (0) 51- 587 3044 + 55 (0) 51- 587 2271 webermt.@webermt.com.br

> **Vibration plates**

> **Vibrating tampers**

> **Vibration rollers**

> **Joint cutters**

> **Internal vibrators and converters**

> **Rollers**



Weber MASCHINENTECHNIK GmbH

Im Boden

57334 Bad Laasphe-Rückershausen

Telephone +49 (0) 27 54 / 398-0 – Fax +49 (0) 27 54 / 398-101