

# Operating and Maintenance Manual



**DVH 655 E-2**

0140302



## Table of contents

Introduction	4
Safety guidelines	5
Graphic presentation	8
Device description	9
Technical data	10
Activities prior to starting work	12
Starting	13
Driving and compacting	14
Taking out of operation	16
Maintenance overview	18
Maintenance work	20
Operating fluids and fill levels	27
Troubleshooting	27
Storage	28
Hydraulic circuit diagram	29
Electrical circuit diagram	30

## Introduction

This operating and maintenance manual is designed to facilitate familiarization with your roller, and to enable you to maintain the compactor and use it for its intended purpose.

When complying with the instructions in the operating and maintenance manual you help avoid hazards, reduce repair and downtime costs, and increase the reliability and service life of your roller.

This operating and maintenance manual must always be available at the implementation site of the roller.

If necessary you can obtain additional information from your authorized WEBER dealer, or you can obtain information from one of the contact addresses on the last page.

The valid conformity declaration is enclosed with every machine delivery.

You can obtain information on the assembled Kohler diesel engine at **[www.kohlerpower.it](http://www.kohlerpower.it)**

You can obtain the current spare parts list of the machine in the WeberMT Service App or use the link below:



<https://www.webermt.com/DE/deu/ersatzteillistenspare-parts-dvh/dvh-655-e-2/>

# Safety guidelines

## General

All safety instructions must be read and complied with, non-compliance results in

- Danger to life and limb of the user
- Impairments to the machine or other property.

In addition to the operating manual, the accident-prevention regulations in the country where the appliance is used must be complied with.

### Intended use

The roller should only be used in technically faultless condition, as intended, in a safety-conscious and hazard-conscious manner, in compliance with the instructions in the operating manual.

Malfunions that impair safety must be eliminated without delay.

The DVH 655 roller is designed exclusively for compacting

- bituminous material (road surfaces); and
- light compaction tasks for earth works

Any other use of the roller is considered to be non-intended use, for which the customer is exclusively responsible. All liability is rejected if damage occurs due to non-compliance with this provision. This risk is borne solely by the user.

### Easily foreseeable misuse

Any use for which the machine is not intended.

### Operating

Rollers are only permitted to be operated by suitable persons of at least 18 years of age. Operators must be instructed in how to guide the roller by the owner or by owner's assigned personnel. The machine operator must comply with traffic regulations. If instructions that affect safety are given by third parties, then the operator must be authorized to reject these instructions.



Unauthorized persons are forbidden from being in the area of the roller during the compacting process.

### Protective equipment

This machine is capable of exceeding the permissible sound level of 80 dB(A). The owner might also face additional dangers when using the machine. Precautionary action must, therefore, be taken.

Protective equipment includes:



Hearing protection



Hard hat



Safety shoes



Protective gloves

## Operation

Prior to starting work the owner of the roller must be familiar with the working environment. The working environment includes obstacles in the work and traffic area, the bearing capacity of the ground, as well as the necessary safeguarding of the construction site in the area adjacent to public traffic; and it also includes compliance with traffic regulations.

The roller should only be operated when the protective fixtures are mounted. The protective fixtures must all be in functional condition.

At least once per shift the roller must be checked for apparent defects. If there are apparent defects then operation of the roller must be stopped immediately, and the responsible person must be informed. Prior to restarting, roller malfunctions that have occurred must be corrected.

Always maintain adequate clearance to the edges of pits and embankments.

Do not drive on slopes in the transverse direction in order to prevent the roller from tipping over. After work has been concluded secure the roller in accordance with statutory regulations, particularly in the area of public traffic surfaces.

## Operation under difficult conditions



Never inhale the exhaust gas; it contains carbon monoxide, a colorless and odorless gas that is extremely hazardous, which if inhaled even briefly can cause unconsciousness and death.

Therefore, never operate the engines in enclosed areas or in areas that are poorly ventilated (tunnels, caves, etc.). Exercise particular caution when operating the engine in the vicinity of people and livestock.

## Prior to maintenance and repair work

Only use **original Weber spare parts** for maintenance or repair work to ensure reliable and safe operation.

Hydraulic hose lines must be checked at regular intervals in accordance with standard engineering practice, or they must be replaced at appropriate intervals, even if no signs of safety-relevant defects are present.

Adjusting tasks, maintenance tasks, and inspection tasks must be carried out on schedule as specified in this operating and maintenance manual. These activities should only be executed by trained personnel.

For repair, maintenance, or inspection work the engine of the roller must be safeguarded against unintentional starting.

All pressurized lines, particularly hydraulic lines and lines of the injection system of the drive motor must be depressurized before performing maintenance or repair tasks.

For maintenance and repair tasks the roller must be placed on a level and stable substrate and must be secured from rolling off or tipping over.

Heavy components and assemblies must be secured to and lifted by hoisting machines that can bear their weight when they are replaced. Ensure that no hazard is caused by raising components or assemblies.

Do not position yourself or work under suspended loads.



If lubricating oils and fuel come into contact with skin, they can cause skin cancer. Upon contact with the skin, clean affected skin with suitable cleaning agent without delay.

## Inspection

Rollers must be inspected in accordance with the corresponding implementation conditions and operating conditions, as needed; however an inspection to ensure operationally safe status must be performed by an expert at least once a year. The results of the inspection must be recorded in writing and must be stored at least until the next inspection.

## Cleaning work

Prior to cleaning the roller with a high-pressure cleaner, protect all accessible energized switches, cable connections, etc. against water penetration by masking them off.

Cleaning tasks should only be executed in areas that are suitable and have been approved for this purpose (oil separator amongst others).

## Disposal

All operating fluids and auxiliary materials must be disposed of in an environmentally-compatible manner in accordance with country-specific regulations.

**Important information for operating and maintenance personnel is marked by pictograms.**



Warning against irritants or materials hazardous to health



Warning against a hazardous place



Warning against a suspended load



Wear ear protection



General regulation



Environmental protection



Hard hat



Safety shoes



Protective gloves

## Graphic presentation

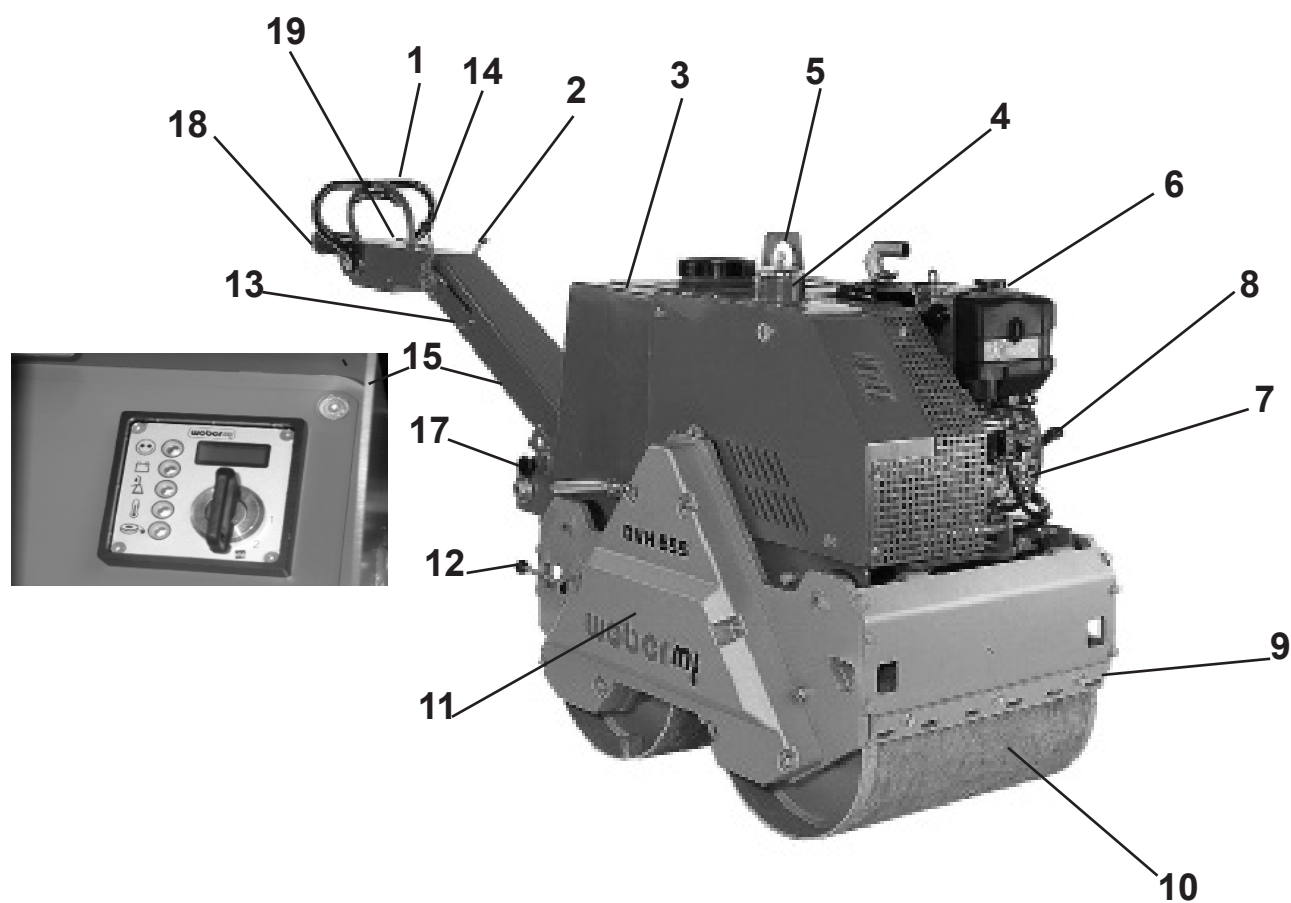

### Overall view DVH 655 E-2

- |                             |                                 |
|-----------------------------|---------------------------------|
| 1 Drive lever               | 9 Scraper                       |
| 2 Vibration lever           | 10 Drums                        |
| 3 Water tank                | 11 Chain guard                  |
| 4 Hydraulic oil filler neck | 12 Parking brake                |
| 5 Lifting ring              | 13 Manual guidance rod          |
| 6 Fuel tank                 | 14 Gas lever                    |
| 7 Engine                    | 15 Ignition lock                |
| 8 Reversing starter         | 16 Battery                      |
|                             | 17 Spring bolt                  |
|                             | 18 Crush guard                  |
|                             | 19 Hearing protection (sticker) |





## **Device description**

The DVH 655 roller is used for compaction work in road building applications.

### **Drive**

The compactor is powered by an air-cooled Kohler diesel engine.

### **Function**

The two drums are hydrostatically powered via chains. The chain drive is executed individually on each bandage. The chain drive also serves as a safety braking system for operating on slopes. The vibrator that is positioned outside between the two drums is powered via a hydraulic motor.

The hydraulic system consists of a closed circuit with hydraulic pumps and hydraulic motors as well as a hydraulic tank.

The drums are freed of adhering material by the adjustable scrapers.

### **Operation**

Start the Kohler diesel engine via the electrical start device.

Use the gas lever to vary the engine speed between idle and full throttle.

Forward and reverse as well as the direction of travel are variably controlled via the drive lever attached to the manual guidance rod.

Also mounted on the manual guidance rod is the lever that is used to switch the vibration on and off.

## Technical data

	DVH 655 E-2
<b>Weight</b>	
Dead weight (in kg)	700
Operating weight CECE in kg	732
<b>Dimensions</b>	
Overall length (in mm)	2310
Overall width (in mm)	805
Height (in mm)	1105
Drum width (in mm)	650
Drum diameter (in mm)	400
Axle base (in mm)	500
Lateral overhang L/R (in mm)	25/130
<b>Drive</b>	
Engine manufacturer	Kohler
Type	KD 15-440
Performance at operating speed in accordance with ISO 3046-1 (kW)	6,3
Combustion process	4-stroke diesel
Operating speed (1/min)	3300
Traversing mechanism hydrostatic	both drums
Movement speed (In km/hours)*	0 - 4.5
Climbing capacity without vibration (in %)*	40
Climbing capacity with vibration (in %)*	30
Operating brake	hydrostatic
Parking brake	mechanical Brake effective at friction $\mu = 0.25$ (steel drum on firm rocky ground) to 20 % = 11.3° slope
<b>Vibration</b>	
System	Central exciter outside of the drums
Drive concept	hydrostatic, connectable
Frequency (in Hz)	62
Amplitude (in mm)	0,35
Centrifugal force (in kN)	21

		DVH 655 E-2
<b>Noise emissions in accordance with 2000/14/EC</b>		
Sound pressure level $L_{PA}$ ascertained in accordance with EN 500, in dB (A)		87
Sound power level $L_{WA}$ ascertained in accordance with EN ISO 3744 and EN 500, in dB (A)		108
<b>Vibration values</b>		
Root-mean-square acceleration value for hand-arm vibration ascertained in accordance with EN 500 in $m/s^2$		3,4
	In accordance with directive 2006/42/EC, complying with the vibration values is the owner's responsibility.	

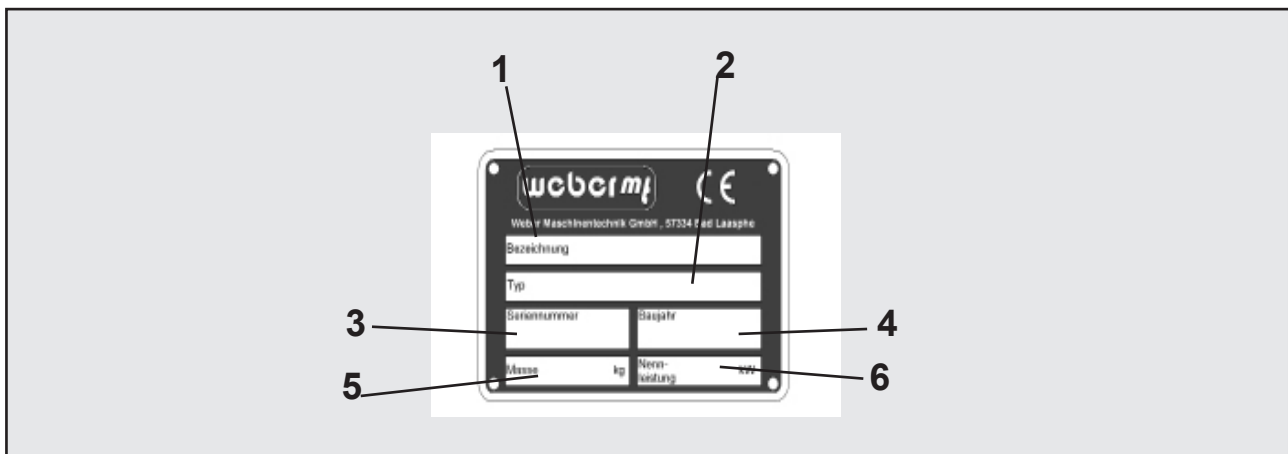

<b>1 Description</b>	<b>2 Type</b>
.....	.....
<b>3 Serial number</b>	<b>4 Year of manufacture</b>
.....	.....
<b>5 Weight</b>	<b>6 Rated power kW</b>

## Activities prior to starting work

### Transport

-  When transporting the soil compactor on a vehicle, secure it with suitable restraints.

Fit the crane hook into the lifting ring (1) and lift the machine onto the desired means of transport.

-  Only use lifting machines with a minimum bearing capacity of 800 kg.

-  Do not step under suspended loads.

Arrest the manual guidance rod (1) with the spring bolt (2).

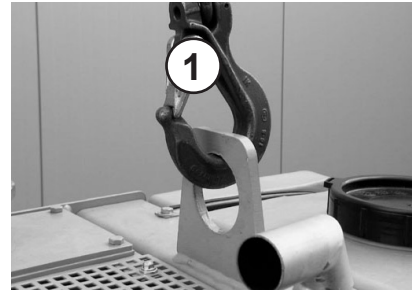

### Check the engine oil level

Pull the oil dip stick (1) out of the crankcase.

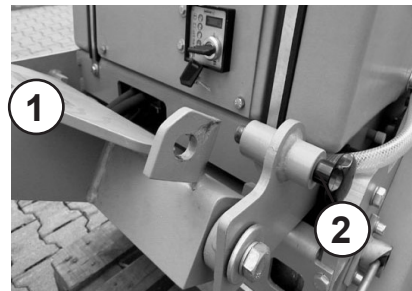



The correct oil level is between the min. and max. marks.



### Check the fuel level

Remove the gas cap (1), check the level, if necessary top off to the lower edge of the filler neck with clean fuel in accordance with the specification.

-  For work at the fuel system, have a suitable fire-extinguishing agent at the ready.

-  Fire, naked light, and smoking is forbidden!

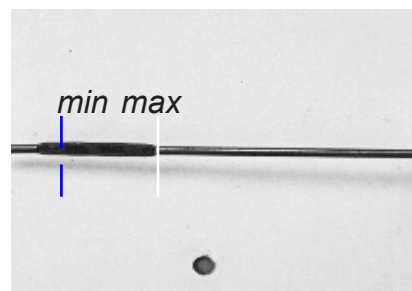

## Check the hydraulic fluid level

Check the hydraulic oil level when the machine is at operating temperature. The correct oil level is reached when the oil is in the middle of the view glass.

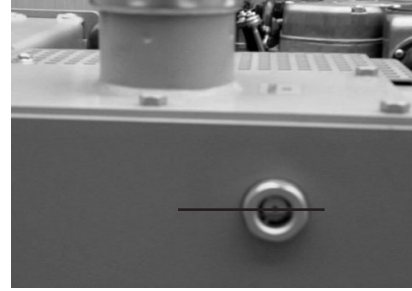

## Start using e-start

Bring the gas lever (1) into full-throttle position.

Move vibration lever (2) to position (  ).

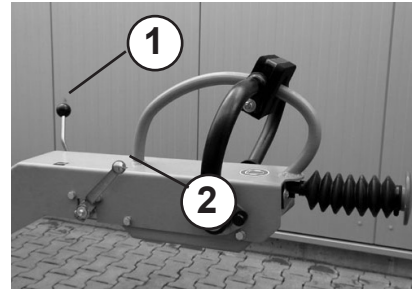

Insert the ignition key (1) and turn to position 1.

Turn the ignition key (1) to position 2.

Release the ignition key as soon as the engine starts

 The ignition key must bounce back to pos. 1 and remain in this position during operation. The charge level indicator (3) and the oil pressure indicator (4) must go out immediately after starting.

The indicator lamp (2) lights up, indicating that the engine is in operation.

The operating hours counter (7) will keep counting the operating hours as long as the ignition is switched on.

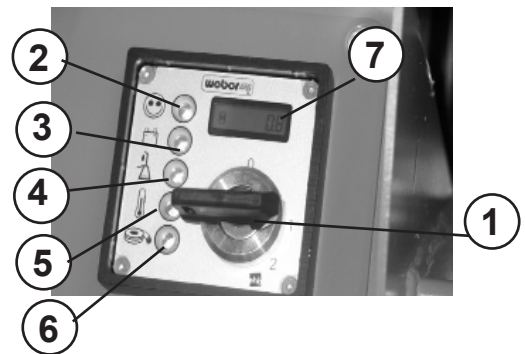

 If the ignition key does not bounce back to pos. 1 - turn off the machine immediately - danger of starter damage due to the starter also running during operation

 Start for a maximum of twenty seconds without interruption. If the engine does not start, repeat starting process after a minute. If the engine does not start after two start processes, seek cause in fault table.

## Start using the reversing starter

Bring the gas lever (1) into full-throttle position.  
Move vibration lever (2) to position (III).

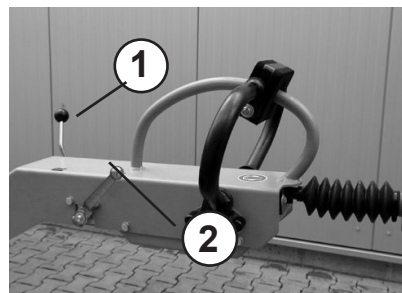

Slowly tighten the handle (1) of the reversing starter (2) until resistance is noticeable.  
Allow the handle (1) to glide back into the initial position, and then forcefully and completely pull it through with both hands.

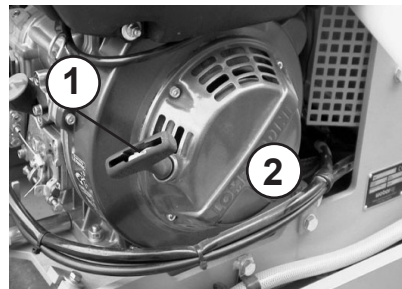

Allow the engine to warm up for a few minutes.

## Driving and compacting

Push the speed control lever (1) to full-throttle position.

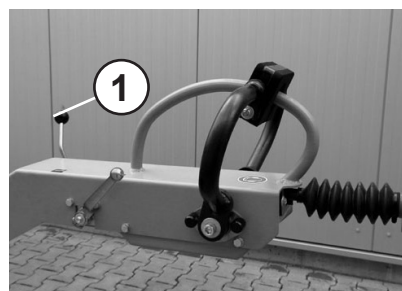

Push the parking brake (1) into vertical position (disengage).

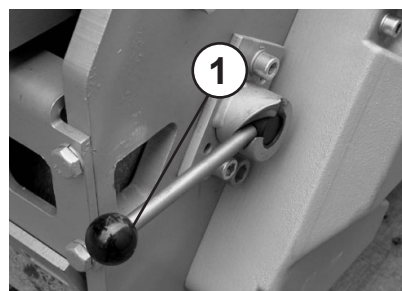

Open water cock (1) if necessary.

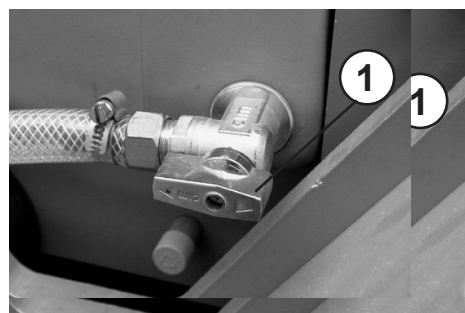

Use the handle (1) to steer the roller in the desired direction.

Push the drive bar (1) into the desired direction of travel.

Move the vibration adjustment lever (2) as far as it will go to position (  ).

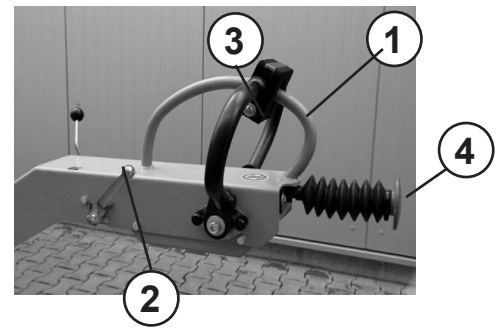

 **Forward**

= Press the drive bar forward

 **Reverse**

= Pull the drive bar back/down

 **Standstill**

= Allow the drive bar to slide into 0 position

 The roller will come to an immediate stop as soon as the drive lever (1) is released.

 If the operator bumps against the crush guard (3) when moving in reverse, the machine comes to a stop.

 Through swinging out the drive lever (1) forward in the direction of travel, the crush protection fixture is again lifted up.

## Compacting

Move the vibration adjustment lever (1) as far as it will go to position (  ).

Push the drive lever (2) into the desired direction of travel.



### Forward

= Press the drive lever forward



### Reverse

= Pull the drive lever back



### Standstill

= Allow the drive lever to slide into 0 position



Change the direction of travel in good time.



At obstructions (walls, pits, etc.), ensure that no one can be caught between the machine and the obstruction; or ensure that the machine does not slip into the pit.

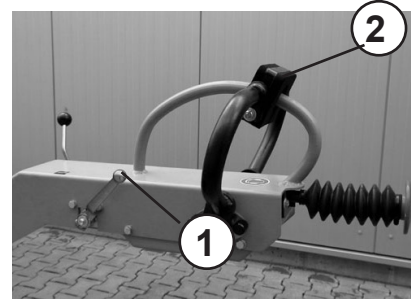

## Shut off

Push back gas lever and let engine run idle for a few minutes.

Move vibration lever to position  .

Close water shut-off valve (1) if necessary

Press down the parking brake (1) (horizontal) until it locks in place.

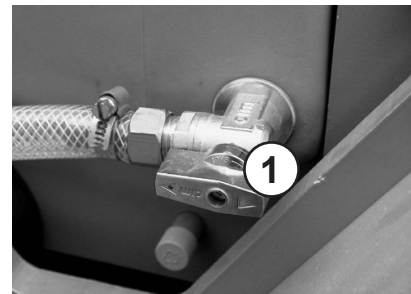

Push the stop lever (1) of the engine to the left.

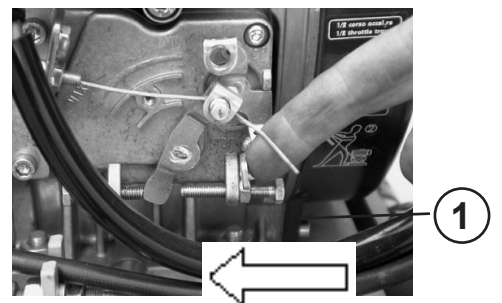



Turn the ignition key (1) from position „I“ to position „0“.  
Pull out the ignition key.

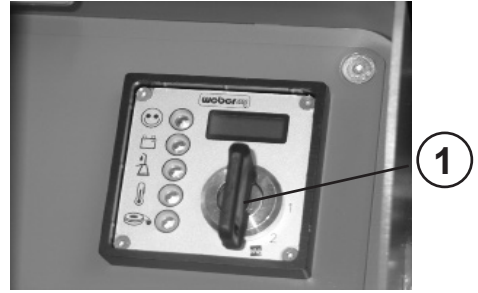

Lock the vandalism flap (1) with a padlock.

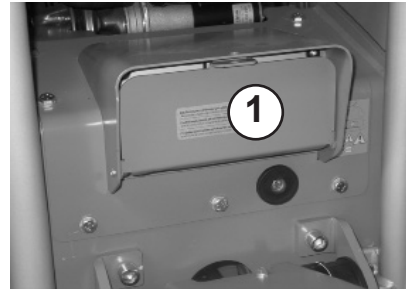



⚠ During breaks — even if they are short — the machine must be shut down.

⚠ Parked devices that represent an obstacle must be safeguarded against conspicuously.

## Maintenance overview

Maintenance interval	Maintenance point	Maintenance activity
<b>After the first 50 operating hours</b>	Hydraulic system	- Change hydraulic fluid filter
	Engine	- Change engine oil
<b>Every 8 operating hours/ daily</b>	Air filter	- Clean air filter insert, check for damage, replace if necessary
	Hydraulic system	- Check threaded unions, hoses for leaks, tighten threaded unions or change hoses as needed  - <b>Only perform work if the hydraulic system is de-pressurized!!</b>
	Engine	- Check the engine oil level
<b>Every 150 operating hours/ every 6 months</b>	Vibration shaft	- Check V-belt for damage
	Engine	- Change oil filter and engine oil - Change the fuel filter
	Drive chains	- Lubricate, retighten if necessary
	Scraper	- Visually inspect or readjust
<b>Every 300 operating hours/ every 6 months</b>	Complete roller	- Check all modules for visible damage and wear - Remove fouling, old grease and rust
	Hydraulic system	- Change hydraulic fluid filter - Change hydraulic fluid
	Water tank + sprinkling system	- Clean, remove lime scale
	Drive	- Check drive chains and drive pinion for wear; retighten as needed

 The regulations of the engine manufacturer must be complied with in addition to the above maintenance overview!

 Work must be carried out using regulation tools and the operating and maintenance manual must be complied with for all work.

 All maintenance work: Select a collection vessel that is large enough to prevent oil from spilling onto the ground. Dispose of waste oil in an environmentally friendly manner (regulation on waste oils).

 Dispose of oils, greases, cloths soaked in oil, and replaced parts with oil on them in an environmentally friendly manner.

 If lubricating oils and fuel come into contact with skin, they can cause skin cancer. Upon contact with the skin, clean affected skin with suitable cleaning agent without delay.

 If accessible during maintenance, check the condition and stability of all screws.

## Maintenance work

### Change engine oil

Remove the cover cap (1).

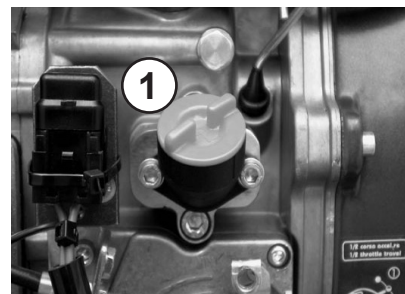

Screw the oil drain pipe (1) onto the engine drain valve and drain off the oil.

 Only drain engine oil when at operating temperature.

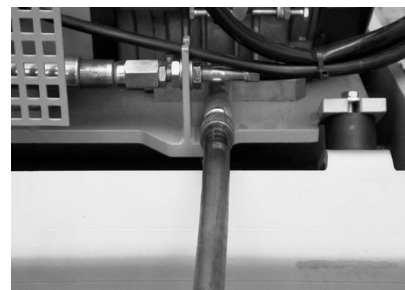

After emptying completely, unscrew the oil drain pipe from the drain valve and fill with oil in accordance with the specification.

Use an oil dip stick (1) to check the oil quantity.

 Danger of scalding due to hot oil.

 When working in the area of the engine compartment there is a danger of being burnt!



### Changing the engine oil filter

Completely drain the engine oil as previously described. Remove the cover cap (1).

 Danger of scalding due to hot oil.

Replace oil filter (1) with a new element. After replacing the filter element, seal the filter enclosure with the cover cap.

 When working in the area of the engine compartment there is a danger of being burnt!

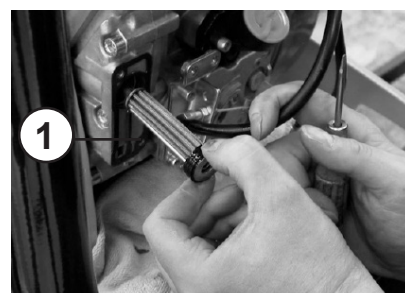

## Change the fuel filter

Pull the fuel line (2) off the fuel filter (1) on both sides.  
Replace the filter with a new filter element.



If lubricating oils and fuel come into contact with skin, they can cause skin cancer. Upon contact with the skin, clean affected skin with suitable cleaning agent without delay.

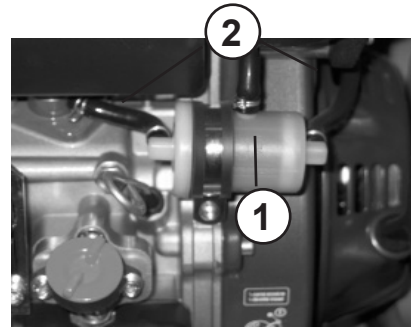

## Clean/change air filter cartridge

Unscrew the air filter cover (1).

Remove the air filter insert (1) from the air filter enclosure.  
Clean air filter insert as specified by the engine manufacturer if there is damage or if it is extremely dirty.

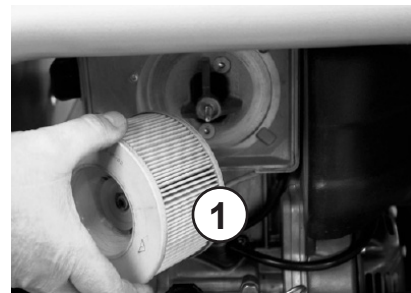

## Checking the battery / acid level



Battery acid is extremely caustic. Protect hands and eyes with suitable protective goggles and gloves.

Remove the cover cap (1).  
Check acid level. If insufficient, fill to max. mark with distilled water.



When removing the battery, start by disconnecting the cable clamp from the negative pole.

Installation is performed in the reverse order of removal.

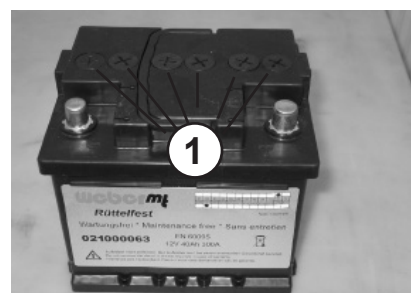

## Lubricate the drive chain

Remove the chain guard (1).

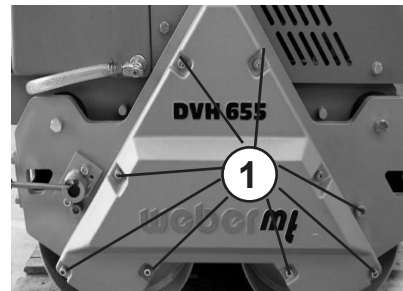

Lubricate the chains (1) as needed and in accordance with the specification.

 Refit the chain guard when finished lubricating the chains.

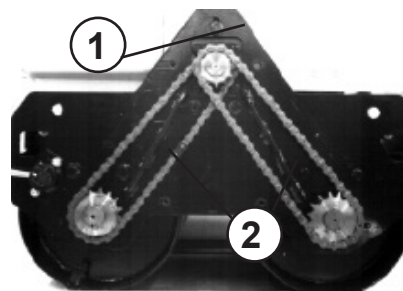

## Check/tighten drive chains

Remove the chain guard (1).



Check the tension of the chains (1).

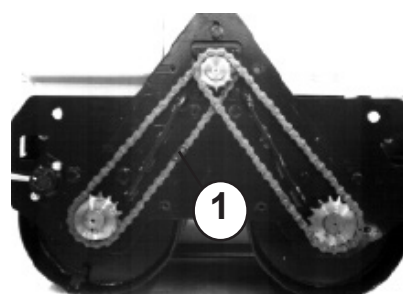

Loosen the fastening screws (1) of the hydraulic motor to tighten the chains.

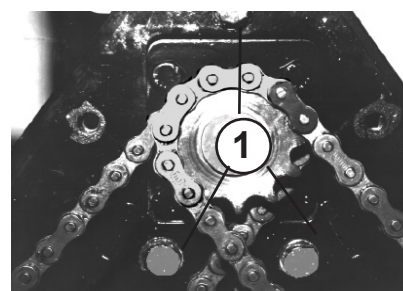

Lift hydraulic motor (1) until the chains (2) have reached the desired tension.

Firmly tighten the screws (3) when finished tightening the chains.

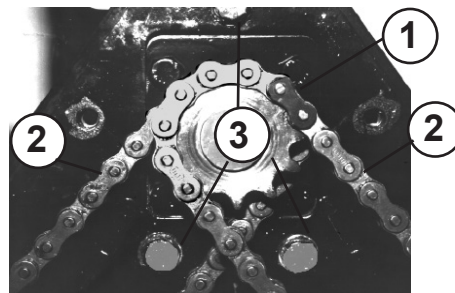

Fasten the chain guard (1).



## Change hydraulic fluid

- ⚠ Always drain the hydraulic fluid when the roller is at a standstill

Open the tank cap (1).



Remove the protective grating (1).

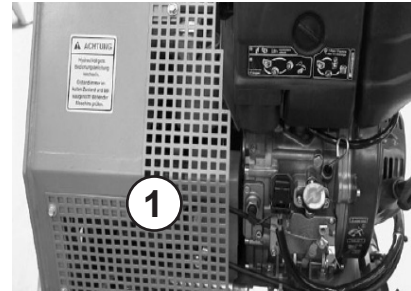

Remove the protective cap (1) from the drain connection (2).

Screw the drain hose onto the drain connection (2).

- ⚠ As soon as the drain hose is screwed on, the drain valve will open.

- ⚠ Danger of scalding due to hot hydraulic oil.

Allow the old oil to drain out completely.

Replace the protective cap (1).

Use the oil filler neck to fill in hydraulic oil in accordance with the specification.

Remove the protective cap (1).

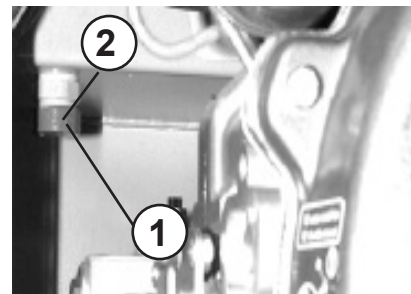

Check the hydraulic fluid level in the view glass (1).

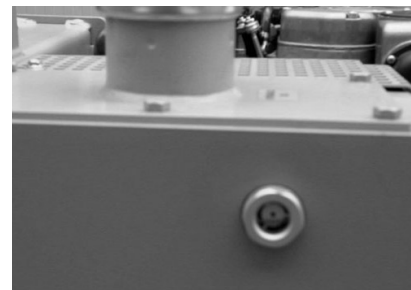



## Change hydraulic fluid filter

Drain hydraulic oil.

Remove the protective grating (1).

Unscrew the hydraulic oil filter (2).

Lightly oil the rubber seal of the hydraulic oil filter.

Screw on new hydraulic oil filter.

 Only hand tighten the hydraulic fluid filter.

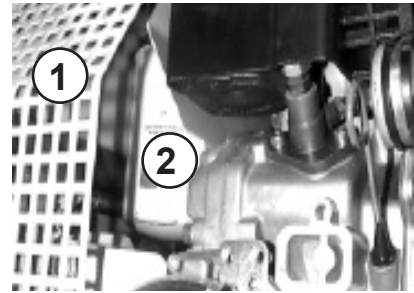

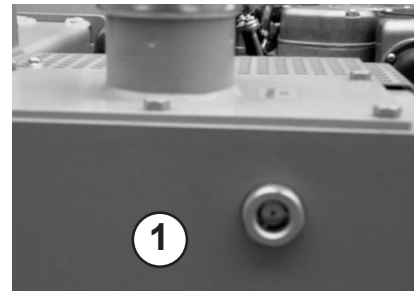

Top up hydraulic liquid.

Check the hydraulic fluid level in the view glass (1).



 Check the hydraulic oil level when the machine is at operating temperature. The correct oil level is reached when the oil is in the middle of the view glass.

 If lubricating oils and fuel come into contact with skin, they can cause skin cancer. Upon contact with the skin, clean affected skin with suitable cleaning agent without delay.

 All maintenance work: Select a collection vessel that is large enough to prevent oil from spilling onto the ground. Dispose of waste oil in an environmentally friendly manner (regulation on waste oils).

 Wipe up/off oil slick and oil residue and dispose of fuel-soaked cleaning cloths in an environmentally responsible manner.

## Change vibrator oil

Remove water tank.  
Unscrew oil filler screw (1).

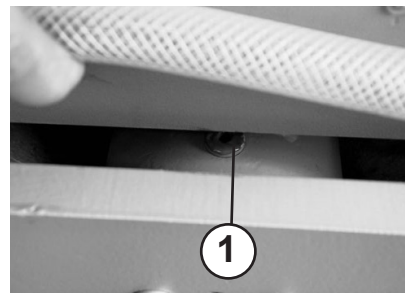

Lift roller.

Unscrew oil drain screw (1).



Do not step under suspended loads.

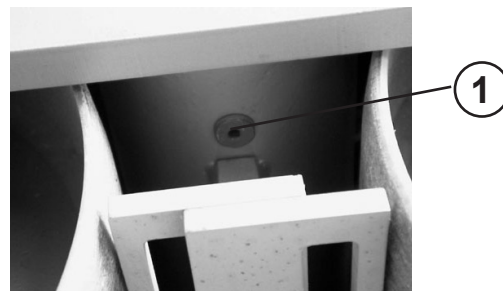

Screw in oil drain screw (1).  
Fill in vibrator oil in accordance with the specification.  
Screw in oil filler screw.



All maintenance work: Select a collection vessel that is large enough to prevent oil from spilling onto the ground. Dispose of waste oil in an environmentally friendly manner (regulation on waste oils).



Dispose of oils, greases, cloths soaked in oil, and replaced parts with oil on them in an environmentally friendly manner.

## Adjust the scraper

Loosen the three screws (1) on each of the scrapers.  
Slide the scraper closer to the respective drum.

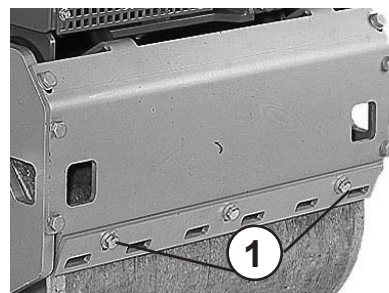

 The scrapers should not touch the drums.  
Securely tighten the screws.



## Operating fluids and fill levels

Assembly	Operating material		DVH 655 E-2
	Summer	Winter	
<b>Engine</b> Engine oil	SAE 10 W 40 (-10 ~ + 50 °C) API - CD CE or SHPD or CCMC - D2 - D3 - PD1		1.5 l
<b>Fuel tank</b> Diesel	Diesel	Winter diesel fuel (from approx. -12 °C) *  Diesel in accordance with DIN 51601-DK or BS2869-A1/A2 or ASTM D975-1D/2D	5.0 l
<b>Hydraulic system</b>	Hydraulic fluid (ISO) H-LP 68 Kinem. viscosity 68mm <sup>2</sup> /s (cSt) at +40°C First filling: Fuchs Renolin MR 68MC Multigrade oil		12.0 l
<b>Water tank</b>	Clean water		60.0 l
<b>Lubricating points</b>	High pressure grease (lithium saponified), in accordance with DIN 51502 and 51825 KP2N-30, to 150°C		As necessary
<b>Battery</b>	Distilled water		As necessary

## Troubleshooting

Fault	Possible cause	Remedy
<b>Roller does not start</b>	Operating error	Execute the start process as prescribed
	Lack of fuel	Check the fuel level
	Fuel filter fouled	Change the fuel filter
	Air filter fouled	Clean/change air filter cartridge
	Battery defective	Charge/replace battery
	Fuse defective	Changing the fuse
<b>Roller does not move</b>	Operating error	Repeat movement attempt
	Hydraulic pump is no longer working	Check the V-belt for the hydraulic pump; replace if necessary

## Action to be take before long-term storage (longer than a month)

<b>Entire soil compactor</b>	<ul style="list-style-type: none"> <li>- Clean thoroughly</li> <li>- Check watertight</li> <li>- If there are leaks, correct defects</li> </ul>
<b>Fuel tank</b>	<ul style="list-style-type: none"> <li>- Empty fuel and fill with clean fuel up to the lower edge of filler neck</li> </ul>
<b>Engine</b>	<ul style="list-style-type: none"> <li>- Check oil level, if necessary fill to upper oil-level mark</li> <li>- Check air filter, clean, replace if necessary</li> <li>- Check fuel filter, change if necessary</li> </ul>
<b>All bare parts / accelerator / accelerator control cable / fastening bolts</b>	<ul style="list-style-type: none"> <li>- Oil/grease</li> </ul>
<b>Starter battery (if there is one)</b>	<ul style="list-style-type: none"> <li>- Remove battery</li> <li>- Check acid level; if it is too low, fill with distilled water up to max. mark of the battery</li> <li>- Store above freezing in a storage room</li> <li>- Attach permanent charger</li> </ul>



If the machine is to be stored for longer than six months, then contact the Weber service organization to discuss additional measures.



# Electrical circuit diagram

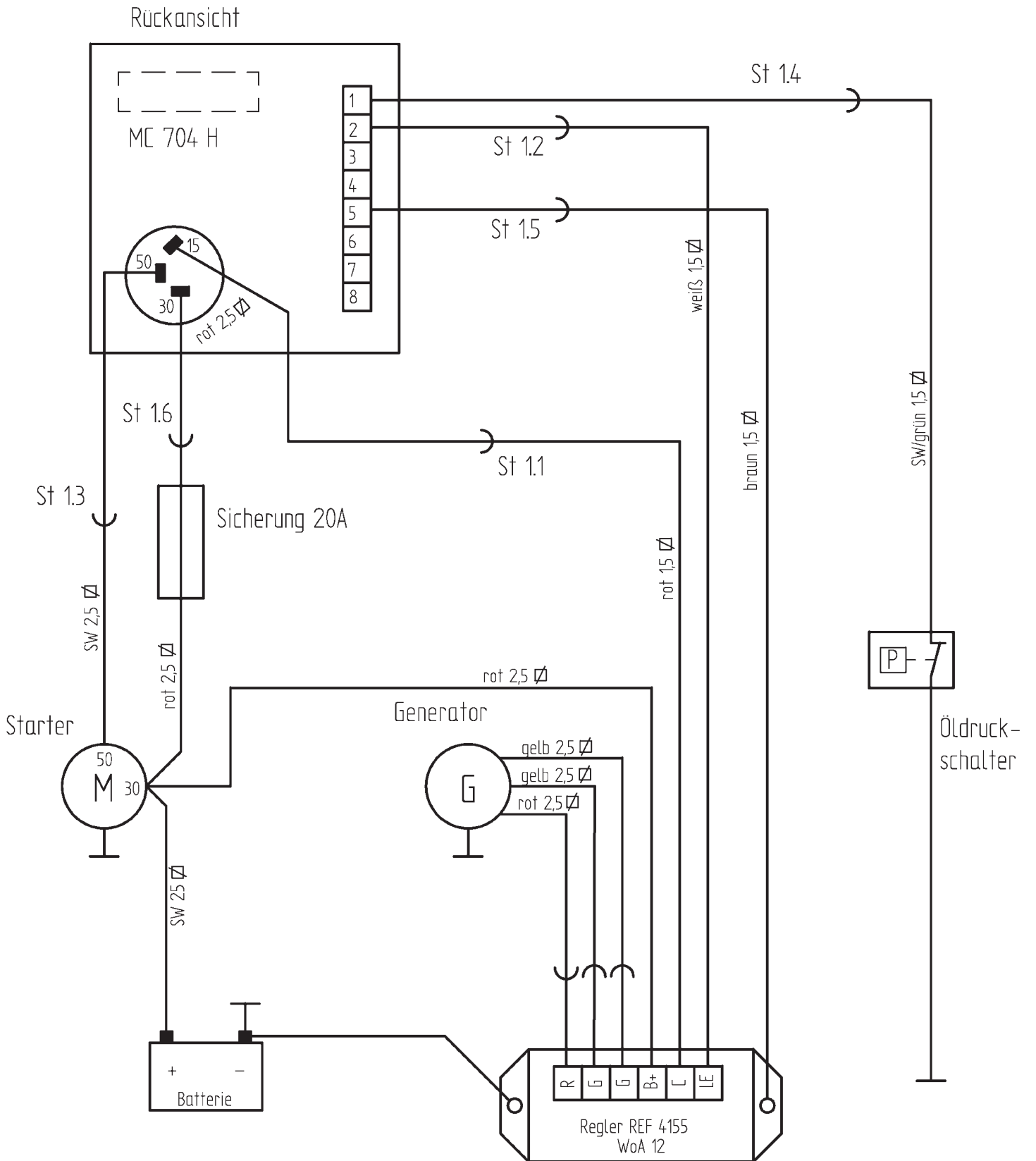





[facebook.com/WeberMT](https://facebook.com/WeberMT)



[youtube.com/MyWeberMT](https://youtube.com/MyWeberMT)



**Weber Maschinentechnik GmbH**

Im Boden 5-8, 10 · 57334 Bad Laasphe · Germany  
Phone +49 2754 398 0 · Fax +49 2754 398 101  
[info@webermt.de](mailto:info@webermt.de) · [www.webermt.de](http://www.webermt.de)

085103053-104 / DVH 655 E-2\_2021-10\_EN  
Original instructions