

# Ersatzteile

Spare parts

Spares

Pièces de rechange

Piezas de recambio

Ricambi

Peças de reposição

Piese de schimb

Náhradných dielov

Reservedele

Części zamienne



## SRV 300-II, SRV 300-II SF

0170057, 0170058

Ab Serien-Nr.



BITTE, NOTIEREN SIE SERIENNUMMER UND MOTORNUMMER IHRER MASCHINE:

PLEASE WRITE DOWN SERIALNUMBERS OF MACHINE AND ENGINE:

NOTEZ SVP LE NUMERO DE SERIE ET LE NUMERO DU MOTEUR DE VOTRE MACHINE:

SI PREGA DI ANNOTARE SEMPRE I NUMERI DI SERIE SIA DELLA VS. MACCHINA CHE DEL MOTORE:

MAQUINA: ROGAMOS ANOTEN EL NUMERO DE SERIE Y NUMERO DE MOTOR DE SU MAQUINA:

PROSIMY ZANOTOWAĆ NUMER MASZYN Y SILNIKA

MASCHINE  
MACHINE  
MACCHINA  
MAQUINA  
MASZYNA

# # #
-------------

MOTOR  
ENGINE  
MOTEUR  
MOTORE  
SILNIK

# # #
-------------

ZUR VERMEIDUNG VON FEHLLIEFERUNGEN UND VERZÖGERUNGEN SIND BEI DER BESTELLUNG VON ERSATZTEILEN FOLGENDE ANGABEN UNBEDINGT ERFORDERLICH:

- MASCHINENTYP
- SERIENNUMMER DER MASCHINE
- SERIENNUMMER DES MOTORS (BEI MOTORTEILEN)
- TEILENUMMER
- BESTELLMENGE

TO AVOID ERRORS IN DELIVERY PLEASE STATE THESE PARTICULARS WHEN ORDERING:

- TYPE OF MACHINE
- SERIAL NO. OF MACHINE
- SERIAL NO. OF ENGINE (ON ENGINE PARTS)
- PART-NO.
- QUANTITY REQUIRED

AFIN D'EVITER DES ERREURS DE COMMANDE ET DES RETARDS DE LIVRAISON IL EST NECESSAIRE D'INDIQUER LES CARACTERISTIQUES SUIVANTES:

- TYPE DE MACHINE
- LE NUMERO DE SERIE DE LA MACHINE
- LE NUMERO DE SERIE DU MOTEUR
- LE NUMERO D'IDENTITE DE LA PIECE
- LA QUANTITE SOUHAITEE

ONDE EVITARE DISGUIDI E RITARDI NELLE CONSEGNE DIE RICAMBI SI PREGA DI INDICARE SEMPRE:

- TIPO DELLA MACCHINA
- NUMERO DI SERIE DELLA MACCHINA
- NUMERO DI SERIE DEL MOTORE (SE SI RICHIEDONO PEZZI DEL MOTORE)
- NUMERO D'ORDINE DIE SINGOLI RICAMBI
- QUANTITA

A FI DE EVITAR ERRORES DE ENTREGA, ROGAMOS INDIQUEN LOS SIGUIENTES DATOS CUANDO PASE PEDIDOS DE RECAMBIO:

- MODELO DE MAQUINA
- NO. DE SERIE DE LA MAQUINA
- NO. DE SERIE DEL MOTOR (EN PIEZAS PARA MOTOR)
- REFERENCIA DEL RECAMBIO
- CANTIDAD PEDIDA

PROSIMY O PODANIE NASTĘPUJĄCYCH DANYCH PRZY SKŁADANIU ZAMÓWIENIA.

- TYP MASZYN
- NUMER SERYJNY MASZYN
- NUMER SERYJNY SILNIKA (PRZY CZĘŚCIACH DO SILNIKA)
- NUMER CZĘŚCI ZAMIEWNNEJ
- ZAMAWIANA ILOŚĆ

## E 3676-0920

Position Ref.No. Repère Posizione Posicion	Menge Quantity Quantité Quantita Cantidad	Teile-Nr. Part-No. No. Référence Nr. d'Ordine No. Referenzia	Hinweis Hints Indications Indicazione Indicaciones	Position Ref. No. Repère Posizione Posicion	Menge Quantity Quantité Quantita Cantidad	Teile-Nr. Part-No. No. Référence Nr. d'Ordine No. Referenzia	Hinweis Hints Indications Indicazione Indicaciones
1	1	11002052					
2	2	25025159					
3	2	21001065					
4	12	20029032	SKM 12				
5	4	25031015	DIN985-M12				
6	1	11002001					

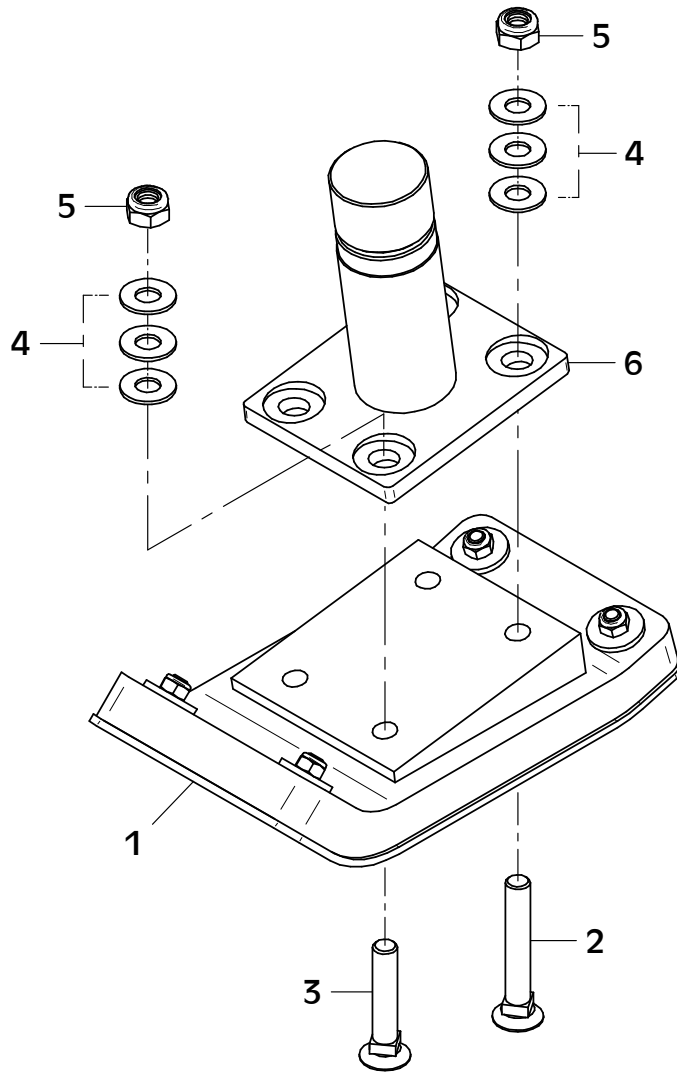

E 3676-0920

## E 3816-0920

Position Ref.No. Repère Posizione Posicion	Menge Quantity Quantité Quantita Cantidad	Teile-Nr. Part-No. No. Référence Nr. d'Ordine No. Referenzia	Hinweis Hints Indications Indicazione Indicaciones	Position Ref. No. Repère Posizione Posicion	Menge Quantity Quantité Quantita Cantidad	Teile-Nr. Part-No. No. Référence Nr. d'Ordine No. Referenzia	Hinweis Hints Indications Indicazione Indicaciones
1	1	12000287					
2	2	25025159					
3	2	21001065					
4	12	20029032	SKM 12				
5	4	25031015	DIN985-M12				
6	1	11002565					

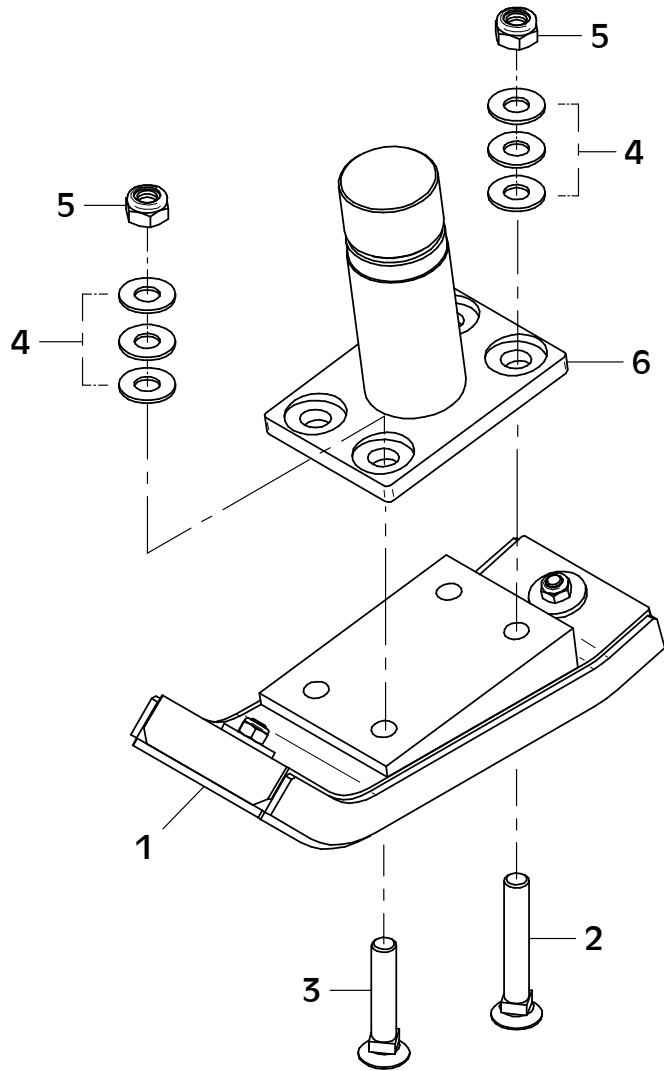

E 3816-0920

## E 3980-1022

Position Ref.No. Repère Posizione	Menge Quantity Quantité Cantidad	Teile-Nr. Part-No. No. Référence Nr. d'Ordine No. Referenzia	Hinweis Hints Indications Indicazione Indicaciones	Position Ref. No. Repère Posizione	Menge Quantity Quantité Cantidad	Teile-Nr. Part-No. No. Référence Nr. d'Ordine No. Referenzia	Hinweis Hints Indications Indicazione Indicaciones
1	1	11002692					
2	3	25038009	DIN933-M8x30				
3	3	20029024	Nord-Lock 8,0				
4	2	11002028					
5	2	20013273					
6	2	11002027					
7	4	25038010	DIN933-M8x35				
8	4	20029031	SKM 8				
9	2	25025195					
10	1	11002007					
11	1	21001066					
12	1	11002004					
13	1	11002029					
14	2	10006971					
15	1	11002008					
16	1	11002009					
17	1	21001062					
18	1	11002108					
19	2	21001064					
20	1	11002005					
21	1	11002006					
22	1	25044013	DIN912-M10x30				
23	1	20025287	S 10				
24	1	21001049					
25	1	21001050					
26	2	21001051					
27							
28	2	11002099					



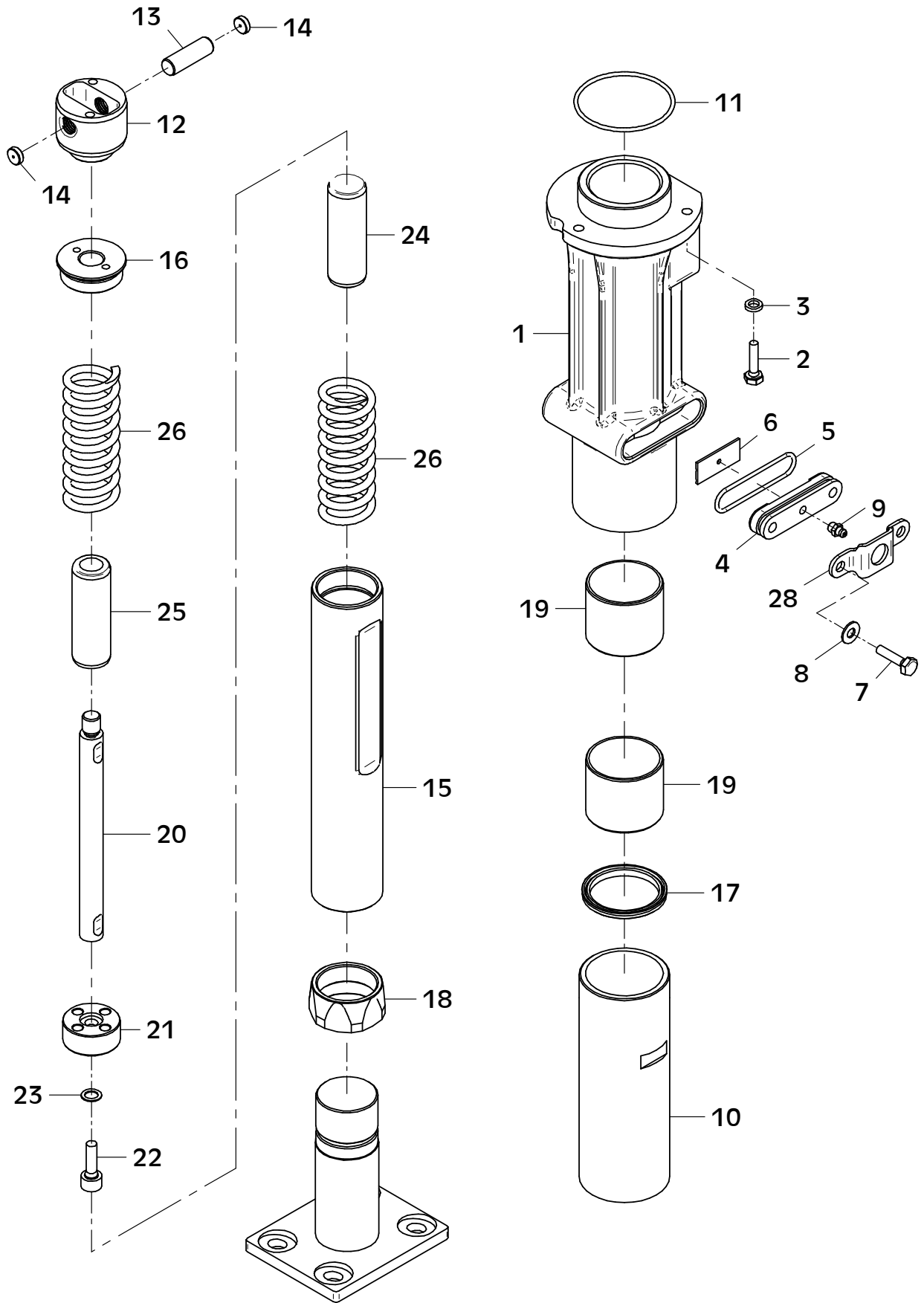

E 3980-1022

## E 3678-0316

Position Ref.No. Repère Posizione	Menge Quantity Quantité Cantidad	Teile-Nr. Part-No. No. Référence Nr. d'Ordine No. Referenzia	Hinweis Hints Indications Indicazione Indicaciones	Position Ref. No. Repère Posizione	Menge Quantity Quantité Cantidad	Teile-Nr. Part-No. No. Référence Nr. d'Ordine No. Referenzia	Hinweis Hints Indications Indicazione Indicaciones
1	1	11001924					
2	1	20013300					
3	1	11001981					
4	2	25038008	DIN933-M8x25				
5	2	20029024	Nord-Lock 8,0				
6							
7	4	25038010	DIN933-M8x35				
8	4	20029024	Nord-Lock 8,0				
9	1	25025195					
10	1	11002055					
11	1	21001074					
12	1	25035003	DIN472-J62x2,0				
13	1	21001056					
14	1	25034006	DIN471-A35x1,50				
15	1	21001058					
16	1	21001057					
17	1	11002032					
18	1	11001983					
19	1	21001055					
20	1	21001059					
21	1	11001993					
22	1	25035012	DIN472-J40x1,75				
23	1	21001057					
24	1	25035003	DIN472-J62x2,0				
25	1	25001011					
26	1	25034005	DIN471-A30x1,50				
27	1	21001054					
28	1	25034003	DIN471-A20x1,20				

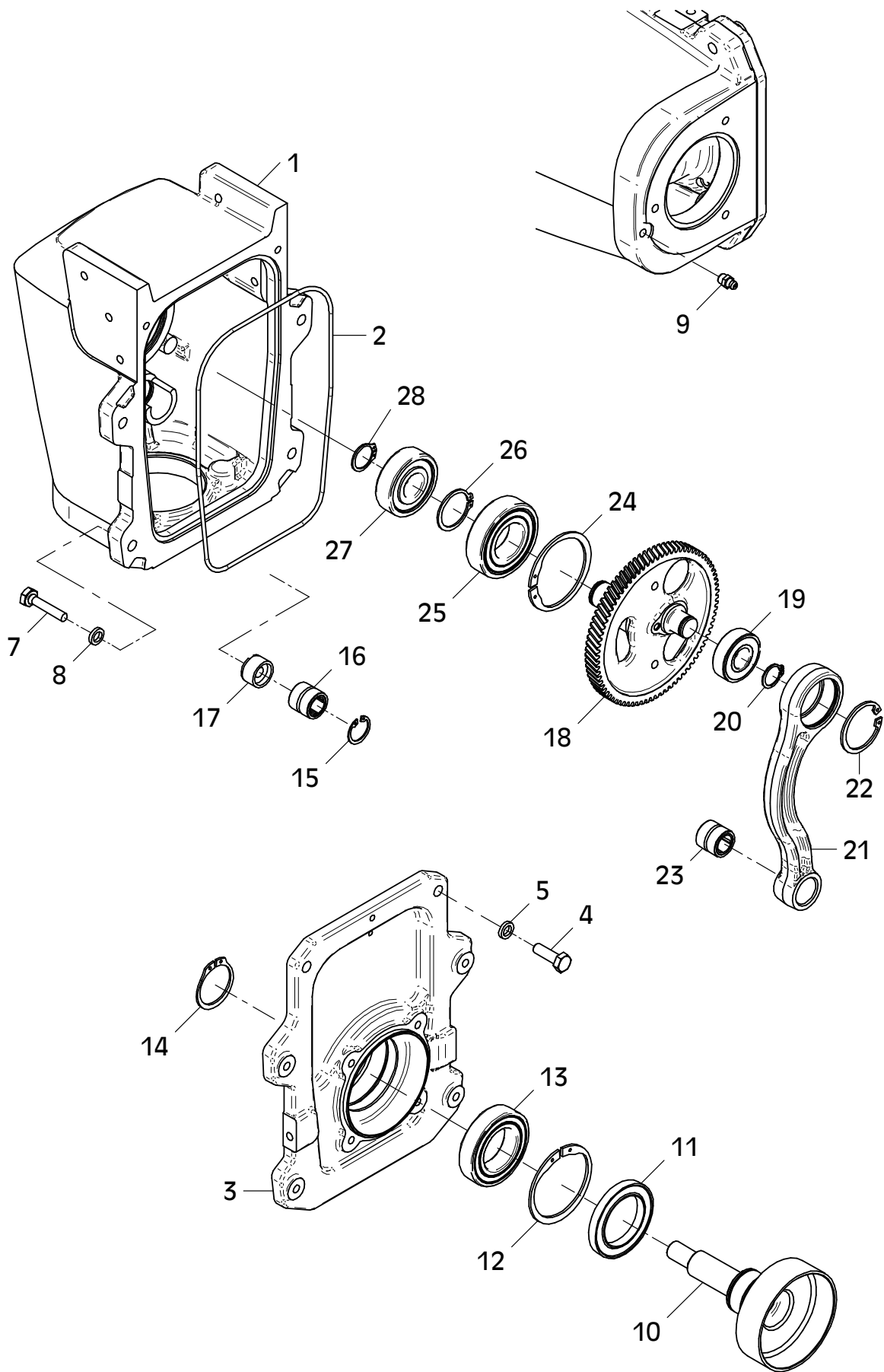

E 3678-0316

## E 3981-1022

Position Ref.No. Repère Posizione	Menge Quantity Quantité Cantidad	Teile-Nr. Part-No. No. Référence Nr. d'Ordine No. Referenzia	Hinweis Hints Indications Indicazione Indicaciones	Position Ref. No. Repère Posizione	Menge Quantity Quantité Cantidad	Teile-Nr. Part-No. No. Référence Nr. d'Ordine No. Referenzia	Hinweis Hints Indications Indicazione Indicaciones
1	1	21001746					
2	4	25044057	DIN912-M6x30				
3	4	20025121					
4	1	21001063					
5	1	11001980					
6	3	25038008	DIN933-M8x25				
7	3	20029024	Nord-Lock 8,0				
8	2	21000258	DIN933-M5x30				
9	2	21000835					
10	2	11002036					
11	2	25027023	DIN914-M6x12				
12	2	21001072	DIN931-M5x50				
13	2	21000835					
14	1	11002738					
15	1	11002739					
16	2	25038007	DIN933-M8x20				
17	2	20029031	SKM 8				
18	2	25038008	DIN933-M8x25				
19	2	20029031	SKM 8				
20	2	20022002	Tensilock M8				
21							
22	2	25044002	DIN912-M6x16				
23	2	25048001	DIN125-A6,4				
24	1	20007007					
25	1	25044074	DIN912-M6x12				
26	1	25048001	DIN125-A6,4				
27	1	20007033					
28	1	25038038	DIN933-M5x16				
29	1	25048017	DIN125-A5,3				

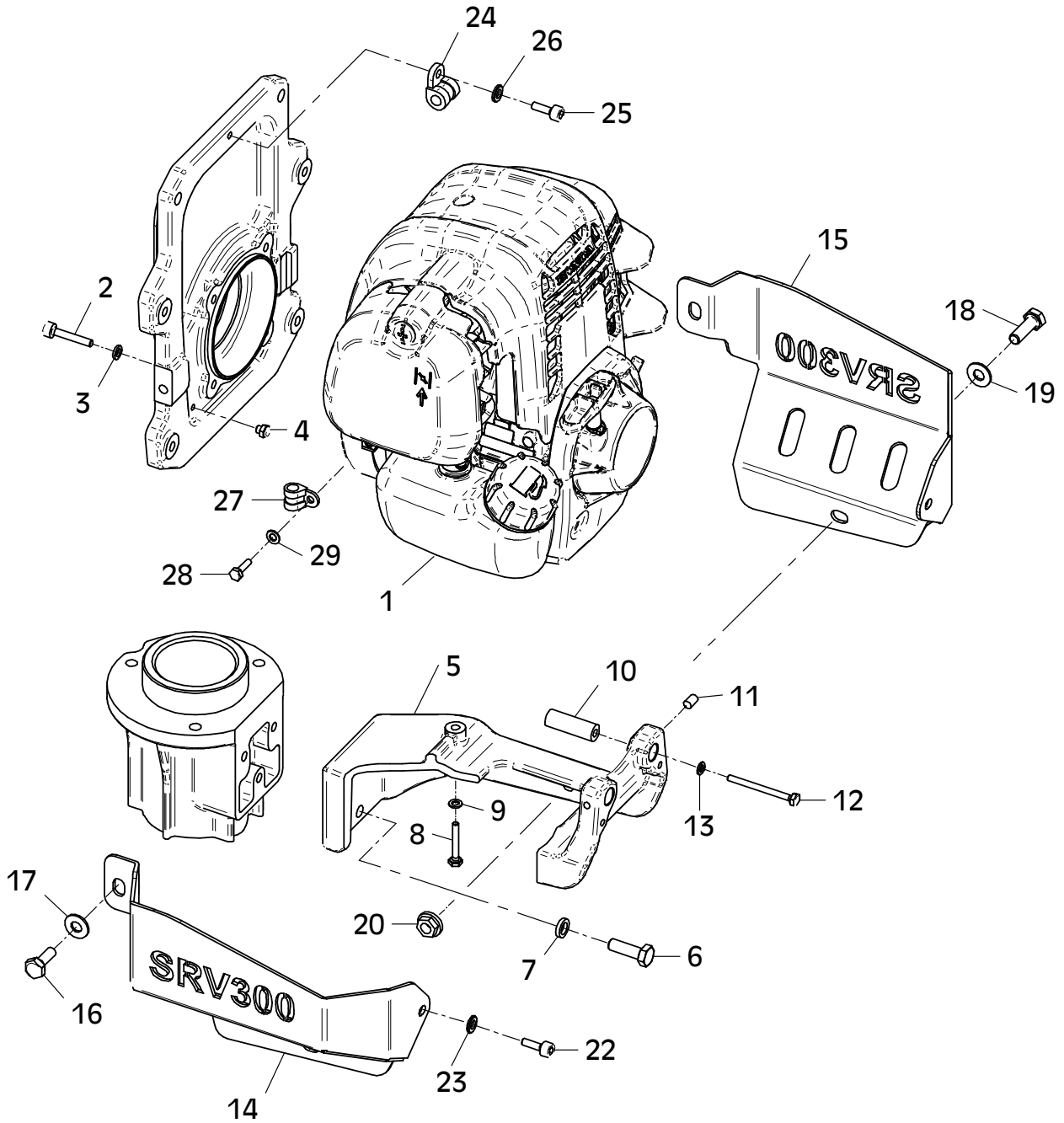
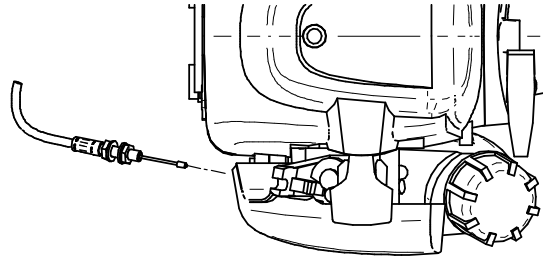

## E 3982-1022

Position Ref.No. Repère Posizione Posicion	Menge Quantity Quantité Quantita Cantidad	Teile-Nr. Part-No. No. Référence Nr. d'Ordine No. Referenzia	Hinweis Hints Indications Indicazione Indicaciones	Position Ref. No. Repère Posizione Posicion	Menge Quantity Quantité Quantita Cantidad	Teile-Nr. Part-No. No. Référence Nr. d'Ordine No. Referenzia	Hinweis Hints Indications Indicazione Indicaciones
1	1	41001685					
2	2	41001476					
3	2	41001478					
4	2	41001477					

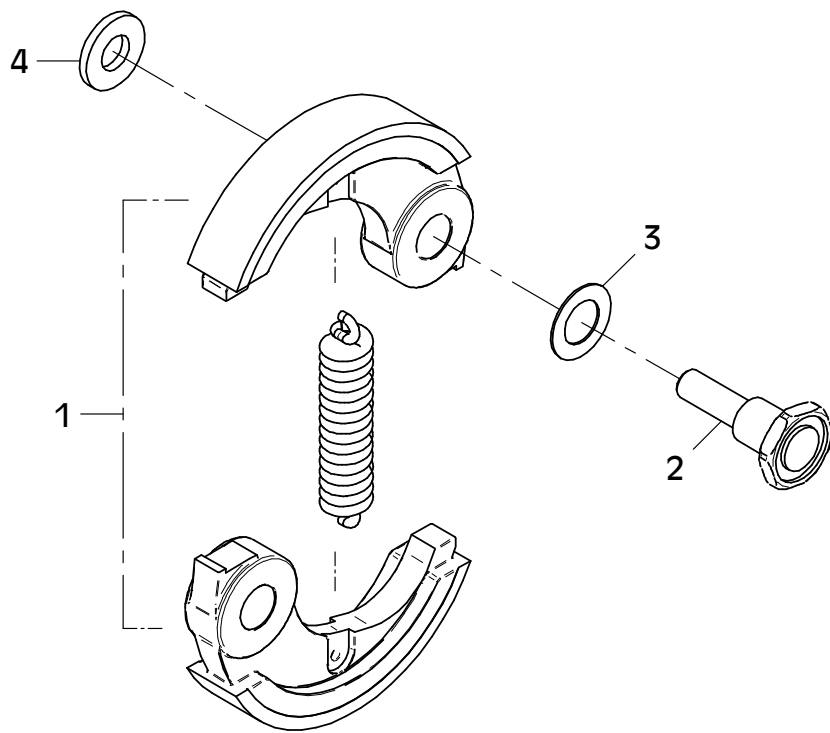

E 3982-1022

## E 3983-1022

Position Ref.No. Repère Posizione Posicion	Menge Quantity Quantité Quantita Cantidad	Teile-Nr. Part-No. No. Référence Nr. d'Ordine No. Referenzia	Hinweis Hints Indications Indicazione Indicaciones	Position Ref. No. Repère Posizione Posicion	Menge Quantity Quantité Quantita Cantidad	Teile-Nr. Part-No. No. Référence Nr. d'Ordine No. Referenzia	Hinweis Hints Indications Indicazione Indicaciones
1	1	41001686					
2	1	41001687					
3	1	41001688					
4	1	41001510					
5	1	41001490					
6	1	41001689					
7	1	41001690					
8	2	41001515					
9	1	41001509					
10	1	41001508					



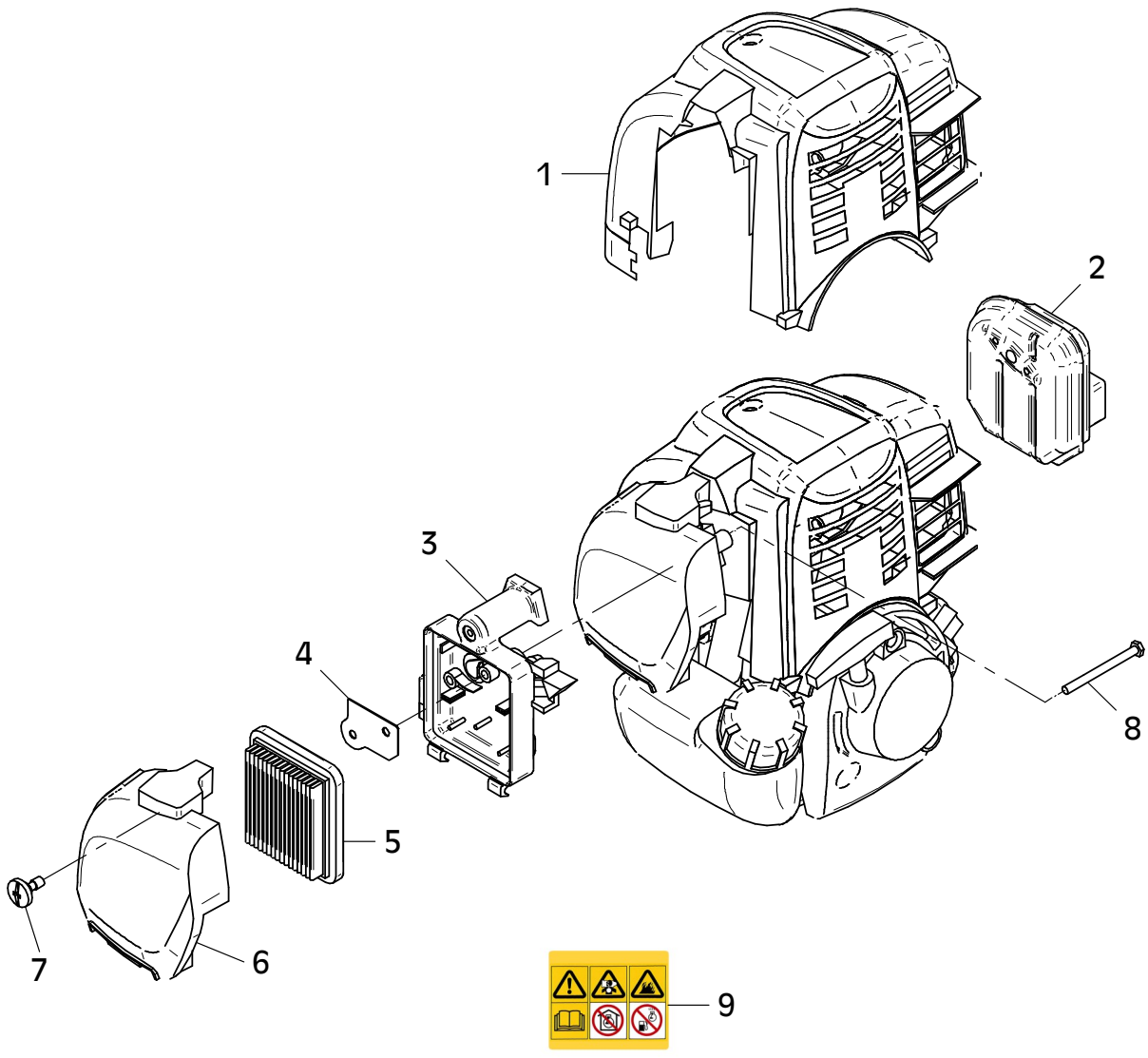

## E 3681-0316

Position Ref.No. Repère Posizione Posicion	Menge Quantity Quantité Quantita Cantidad	Teile-Nr. Part-No. No. Référence Nr. d'Ordine No. Referenzia	Hinweis Hints Indications Indicazione Indicaciones	Position Ref. No. Repère Posizione Posicion	Menge Quantity Quantité Quantita Cantidad	Teile-Nr. Part-No. No. Référence Nr. d'Ordine No. Referenzia	Hinweis Hints Indications Indicazione Indicaciones
1	2	11002011					
2	6	25038008	DIN933-M8x25				
3	6	20029031	SKM 8				
4	2	21000540					
5	1	11001920					
6	8	25038007	DIN933-M8x20				
7	8	20029031	SKM 8				
8	1	11002040					
9	1	11002043					
10	1	11002042					
11	1	11002041					
12	2	25038038	DIN933-M5x16				
13	2	25048017	DIN125-A5,3				
14	2	20022005	Tensilock M5				

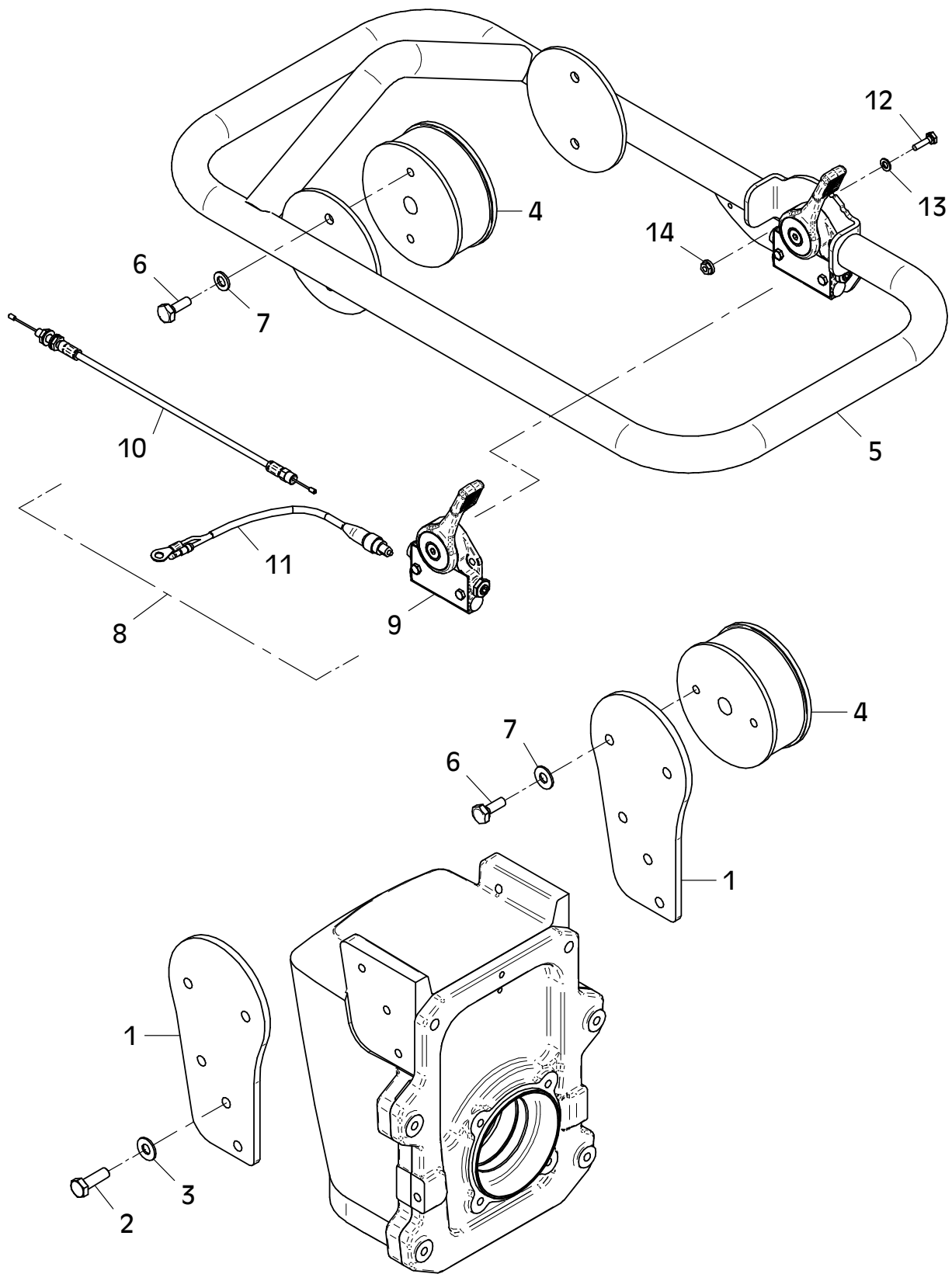

E 3681-0316



[facebook.com/WeberMT](https://facebook.com/WeberMT)



[youtube.com/MyWeberMT](https://youtube.com/MyWeberMT)



**Weber Maschinenteknik GmbH**

Im Boden 5-8, 10 · 57334 Bad Laasphe · Deutschland  
Telefon +49 2754 398 0 · Fax +49 2754 398 101  
[info@webermt.de](mailto:info@webermt.de) · [www.webermt.de](http://www.webermt.de)

085202003 / SRV 300-II\_2023-03