

MA = 28 ± 2Nm

MA = 100Nm

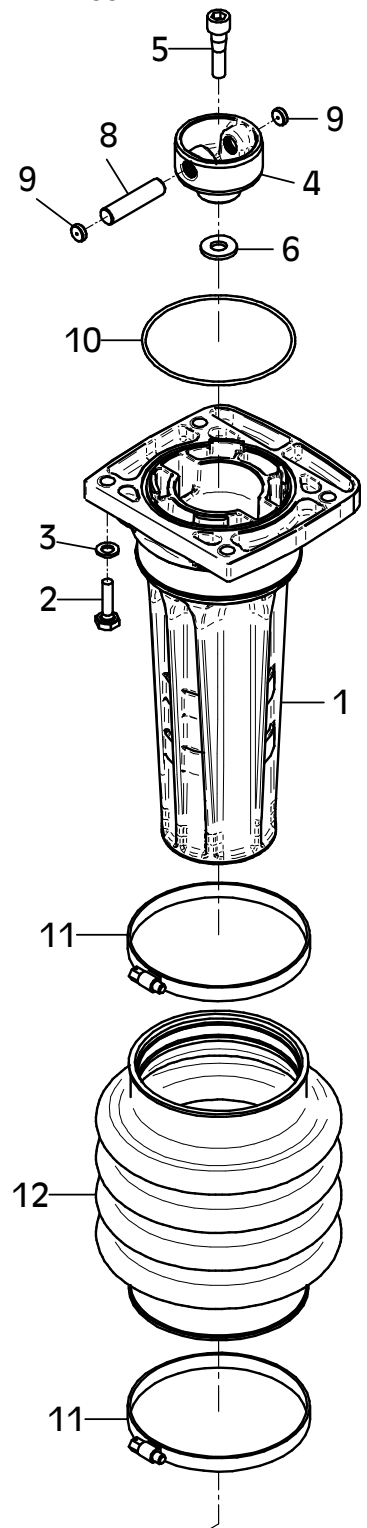

E 3506-0313

E 3506-0313

Position Ref.No. Repère Posizione Posición	Menge Quantity Quantité Quantità Cantidad	Teile-Nr. Part-No. No. Référence Nr. d'Ordine No. Referenzia	Hinweis Hints Indications Indicazione Indicaciones	Position Ref. No. Repère Posizione Posición	Menge Quantity Quantité Quantità Cantidad	Teile-Nr. Part-No. No. Référence Nr. d'Ordine No. Referenzia	Hinweis Hints Indications Indicazione Indicaciones
1	1	11001147					
2	4	25038016	DIN933-M10x35				
3	4	20029001	VSK 10				
4	1	11001280					
5	1	25045037	DIN912-M12x45-10.9				
6	1	25025157					
7							
8	1	10006972					
9	2	10006971					
10	1	21000297					
11	2	20007039					
12	1	20025520					
12	1	21000073	Z				
13	1	11001228					
14	1	25030014	DIN910-G1/2"				
15	1	25008007	DIN7603-21x26x1,5				
16	1	21000755					
17	1	11001227					
18	1	11001477					
19	1	20013067					
20	6	25038009	DIN933-M8x30				
21	6	20029003	VSK 8				
22	1	11001310					
23	1	11001489					
24	1	10006965					
25	1	25045037	DIN912-M12x45-10.9				
26	1	20025158					
27	1	21000733					
28	2	20008053					
29	2	20008035					