

Ersatzteile

Spare parts
Spares
Pièces de rechange
Piezas de recambio
Ricambi
Peças de reposição
Piese de schimb
Náhradných dielov
Reservedele
Części zamienne



CR 2

0115611 – 0115612 , 0115616

Ab Serien-Nr.

BITTE, NOTIEREN SIE SERIENNUMMER UND MOTORNUMMER IHRER MASCHINE:

PLEASE WRITE DOWN SERIALNUMBERS OF MACHINE AND ENGINE:

NOTEZ SVP LE NUMERO DE SERIE ET LE NUMERO DU MOTEUR DE VOTRE MACHINE:

SI PREGA DI ANNOTARE SEMPRE I NUMERI DI SERIE SIA DELLA VS. MACCHINA CHE DEL MOTORE:

MAQUINA: ROGAMOS ANOTEN EL NUMERO DE SERIE Y NUMERO DE MOTOR DE SU MAQUINA:

PROSIMY ZANOTOWAĆ NUMER MASZYNY I SILNIKA

MASCHINE
MACHINE
MACCHINA
MAQUINA
MASZYNA

#

MOTOR
ENGINE
MOTEUR
MOTORE
SILNIK

#

ZUR VERMEIDUNG VON FEHLLIEFERUNGEN UND VERZÖGERUNGEN SIND BEI DER BESTELLUNG VON ERSATZTEILEN FOLGENDE ANGABEN UNBEDINGT ERFORDERLICH:

- MASCHINENTYP
- SERIENNUMMER DER MASCHINE
- SERIENNUMMER DES MOTORS (BEI MOTORTEILEN)
- TEILENUMMER
- BESTELLMENGE

TO AVOID ERRORS IN DELIVERY PLEASE STATE THESE PARTICULARS WHEN ORDERING:

- TYPE OF MACHINE
- SERIAL NO. OF MACHINE
- SERIAL NO. OF ENGINE (ON ENGINE PARTS)
- PART-NO.
- QUANTITY REQUIRED

AFIN D'EVITER DES ERREURS DE COMMANDE ET DES RETARDS DE LIVRAISON IL EST NECESSAIRE D'INDIQUER LES CARACTERISTIQUES SUIVANTES:

- TYPE DE MACHINE
- LE NUMERO DE SERIE DE LA MACHINE
- LE NUMERO DE SERIE DU MOTEUR
- LE NUMERO D'IDENTITE DE LA PIECE
- LA QUANTITE SOUHAITEE

ONDE EVITARE DISGUIDI E RITARDI NELLE CONSEGNE DIE RICAMBI SI PREGA DI INDICARE SEMPRE:

- TIPO DELLA MACCHINA
- NUMERO DI SERIE DELLA MACCHINA
- NUMERO DI SERIE DEL MOTORE (SE SI RICHIEDONO PEZZI DEL MOTORE)
- NUMERO D'ORDINE DIE SINGOLI RICAMBI
- QUANTITA

A FI DE EVITAR ERRORES DE ENTREGA, ROGAMOS INDIQUEN LOS SIGUIENTES DATOS CUANDO PASE PEDIDOS DE RECAMBIO:

- MODELO DE MAQUINA
- NO. DE SERIE DE LA MAQUINA
- NO. DE SERIE DEL MOTOR (EN PIEZAS PARA MOTOR)
- REFERENCIA DEL RECAMBIO
- CANTIDAD PEDIDA

PROSIMY O PODANIE NASTĘPUJĄCYCH DANYCH PRZY SKŁADANIU ZAMÓWIENIA.

- TYP MASZYNY
- NUMER SERYJNY MASZYNY
- NUMER SERYJNY SILNIKA (PRZY CZĘŚCIACH DO SILNIKA)
- NUMER CZĘŚCI ZAMIEWNNEJ
- ZAMAWIANA ILOŚĆ

E 3648-0417

Position Ref.No. Repère Posizione Posicion	Menge Quantity Quantité Quantita Cantidad	Teile-Nr. Part-No. No. Référence Nr. d'Ordine No. Referenzia	Hinweis Hints Indications Indicazione Indicaciones	Position Ref. No. Repère Posizione Posicion	Menge Quantity Quantité Quantita Cantidad	Teile-Nr. Part-No. No. Référence Nr. d'Ordine No. Referenzia	Hinweis Hints Indications Indicazione Indicaciones
1	1	11001836					
1	1	11002705	CR 2/55				
2	1	25030002	DIN908-M14x1,5				
3	1	11001752					
4	1	21000995					
5	12	25038008	DIN933-M8x25				
6	2	20005020					
7	2	25031003	DIN934-M8				
8	4	20004011					
9	4	20029023	SKB 12				
10	4	25031005	DIN934-M12				
11	1	11001835					
12	1	25017047					
13	1	20013295					
14	4	25044005	DIN912-M8x20				
15	4	20029011	VSKZ 8				
16	1	11001754					
17	4	21000589	DIN7964-M8x30				
18	4	20029011	VSKZ 8				
19	12	20029024	Nord-Lock 8,0				
20	2	20029003	VSK 8				

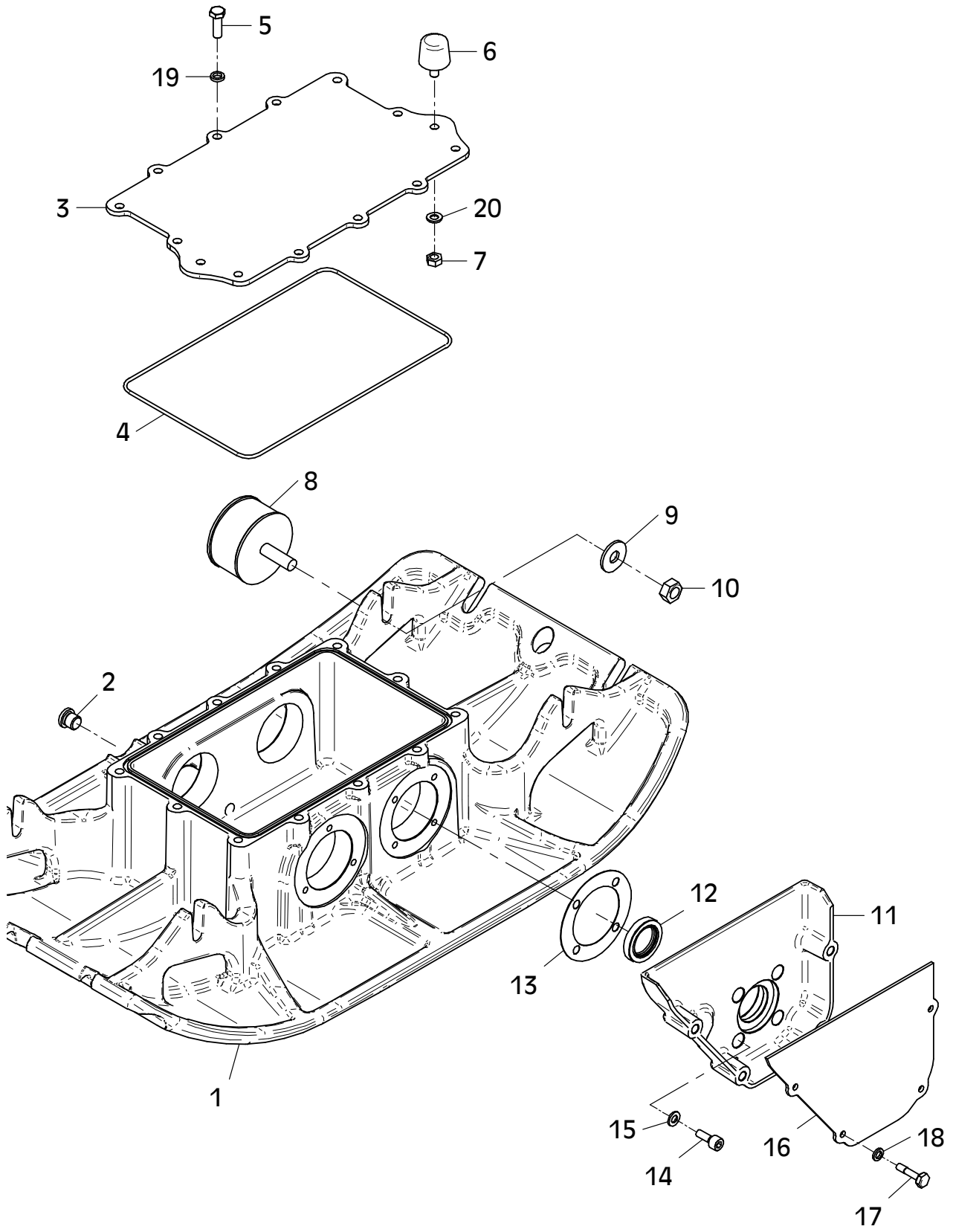

E 3648-0417

E 3649-0216

Position Ref.No. Repère Posizione Posicion	Menge Quantity Quantité Quantita Cantidad	Teile-Nr. Part-No. No. Référence Nr. d'Ordine No. Referenzia	Hinweis Hints Indications Indicazione Indicaciones	Position Ref. No. Repère Posizione Posicion	Menge Quantity Quantité Quantita Cantidad	Teile-Nr. Part-No. No. Référence Nr. d'Ordine No. Referenzia	Hinweis Hints Indications Indicazione Indicaciones
1	2	11001574					
2	2	11001941					
3	6	25044004	DIN912-M8x16-10.9				
4	6	20029011	VSKZ 8				
5	1	11001562					
6	1	11001941					
7	1	20020035					
8	3	25044004	DIN912-M8x16-10.9				
9	3	20029011	VSKZ 8				

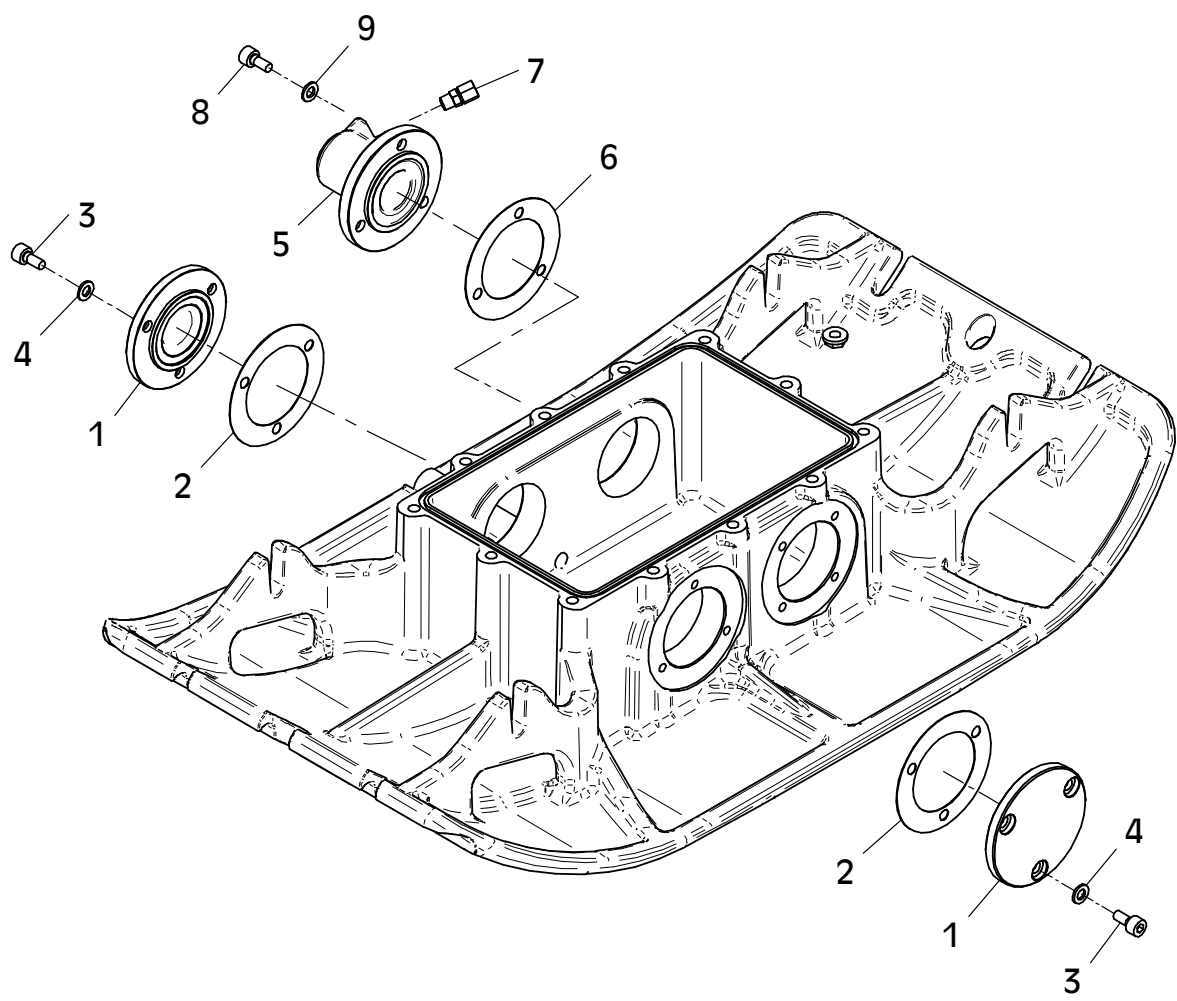

E 3649-0216

E 3650-0617

Position Ref.No. Repère Posizione Posicion	Menge Quantity Quantité Quantita Cantidad	Teile-Nr. Part-No. No. Référence Nr. d'Ordine No. Referenzia	Hinweis Hints Indications Indicazione Indicaciones	Position Ref. No. Repère Posizione Posicion	Menge Quantity Quantité Quantita Cantidad	Teile-Nr. Part-No. No. Référence Nr. d'Ordine No. Referenzia	Hinweis Hints Indications Indicazione Indicaciones
1	1	11001560					
2	1	11001573					
3	1	25001045					
4	1	25034006	DIN471-A35x1,50				
5	1	25035003	DIN472-J62x2,0				
6	2	21000643					
7	1	11002135					
8	1	11002136					
9	3	25044002	DIN912-M6x16				
10	3	20029015	VSKZ 6				
11	1	11001575					
12	2	25045028	DIN912-M10x35-10.9				
13	2	25025245					
14	1	11001559					
15	1	11001942					
16	1	25027022	DIN914-M6x20				
17	1	25001513					
18	1	25034002	DIN471-A12x1,0				
19	1	10016066					
20	1	25035026	DIN472-J28x1,20				
21	1	20013270					
22	1	10016071					
23	1	10007370					
24	1	20029001	VSK 10				

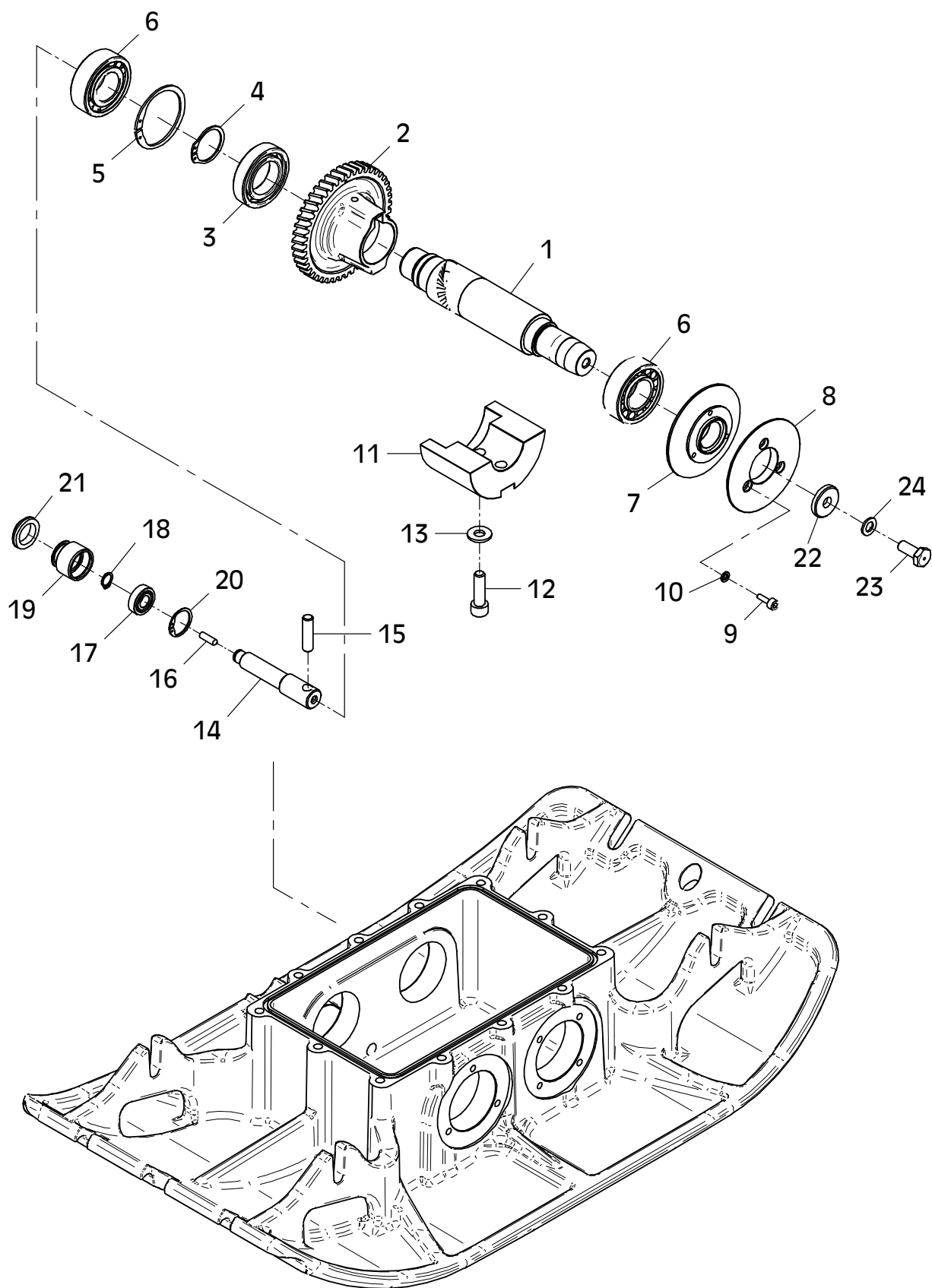

E 3650-0617

E 3651-0216

Position Ref.No. Repère Posizione Posicion	Menge Quantity Quantité Quantita Cantidad	Teile-Nr. Part-No. No. Référence Nr. d'Ordine No. Referenzia	Hinweis Hints Indications Indicazione Indicaciones	Position Ref. No. Repère Posizione Posicion	Menge Quantity Quantité Quantita Cantidad	Teile-Nr. Part-No. No. Référence Nr. d'Ordine No. Referenzia	Hinweis Hints Indications Indicazione Indicaciones
1	1	11001561					
2	1	11001572					
3	1	25015016					
4	2	21000643					
5	1	11001558					
6	2	25045028	DIN912-M10x35-10.9				
7	2	25025245					

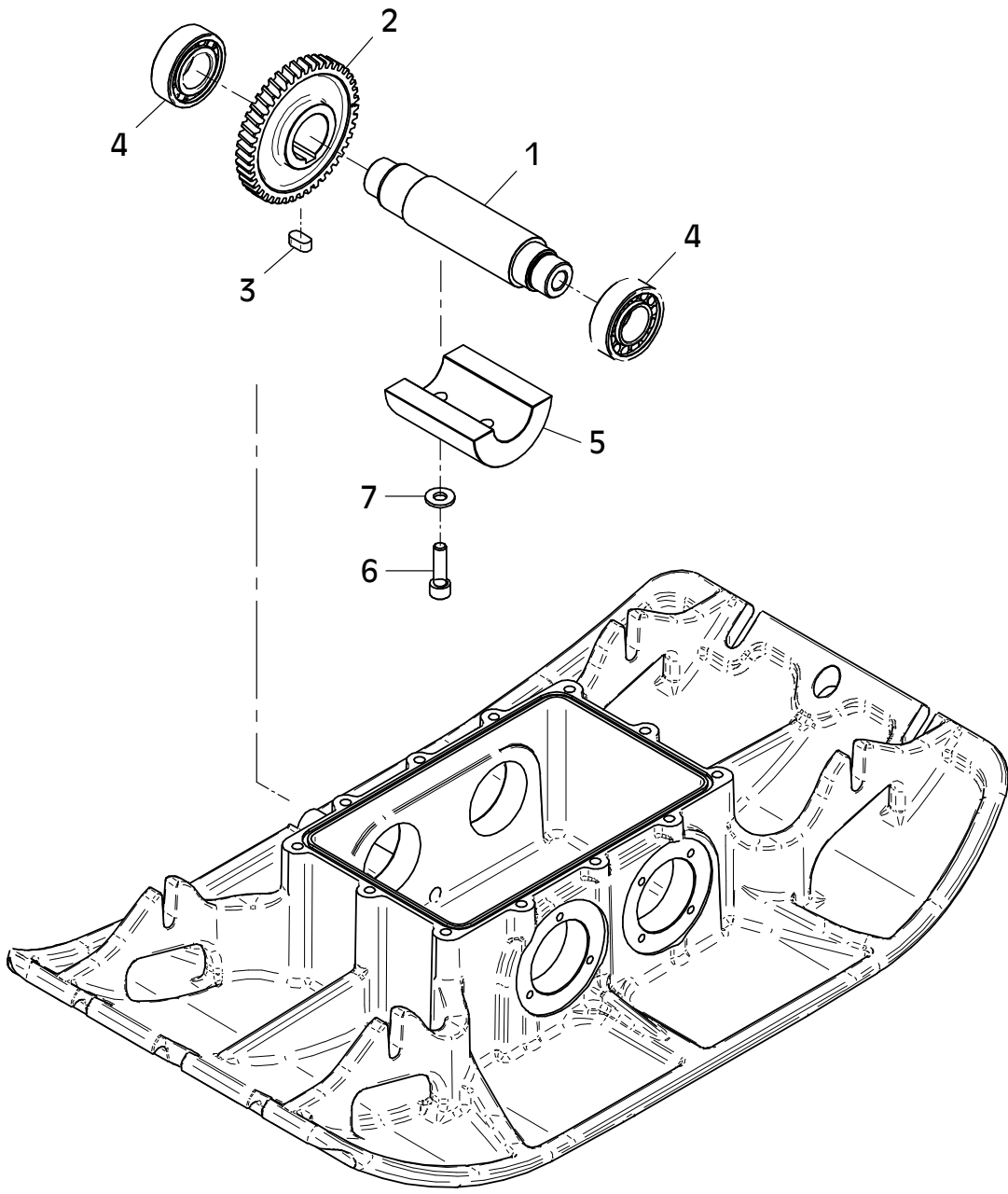

E 3652-0216

Position Ref.No. Repère Posizione Posicion	Menge Quantity Quantité Quantita Cantidad	Teile-Nr. Part-No. No. Référence Nr. d'Ordine No. Referenzia	Hinweis Hints Indications Indicazione Indicaciones	Position Ref. No. Repère Posizione Posicion	Menge Quantity Quantité Quantita Cantidad	Teile-Nr. Part-No. No. Référence Nr. d'Ordine No. Referenzia	Hinweis Hints Indications Indicazione Indicaciones
1	1	11001748					
2	4	21001200	DIN933-M12x18				
3	4	20029023	SKB 12				
4	1	20026465					
5	2	25025191	DIN80705-M20x1,5				
6	2	20025019					
7	1	11001747					
8	4	25038015	DIN933-M10x30				
9	4	25049020	DIN7349-10,5				
10	4	20022003	Tensilock M10				

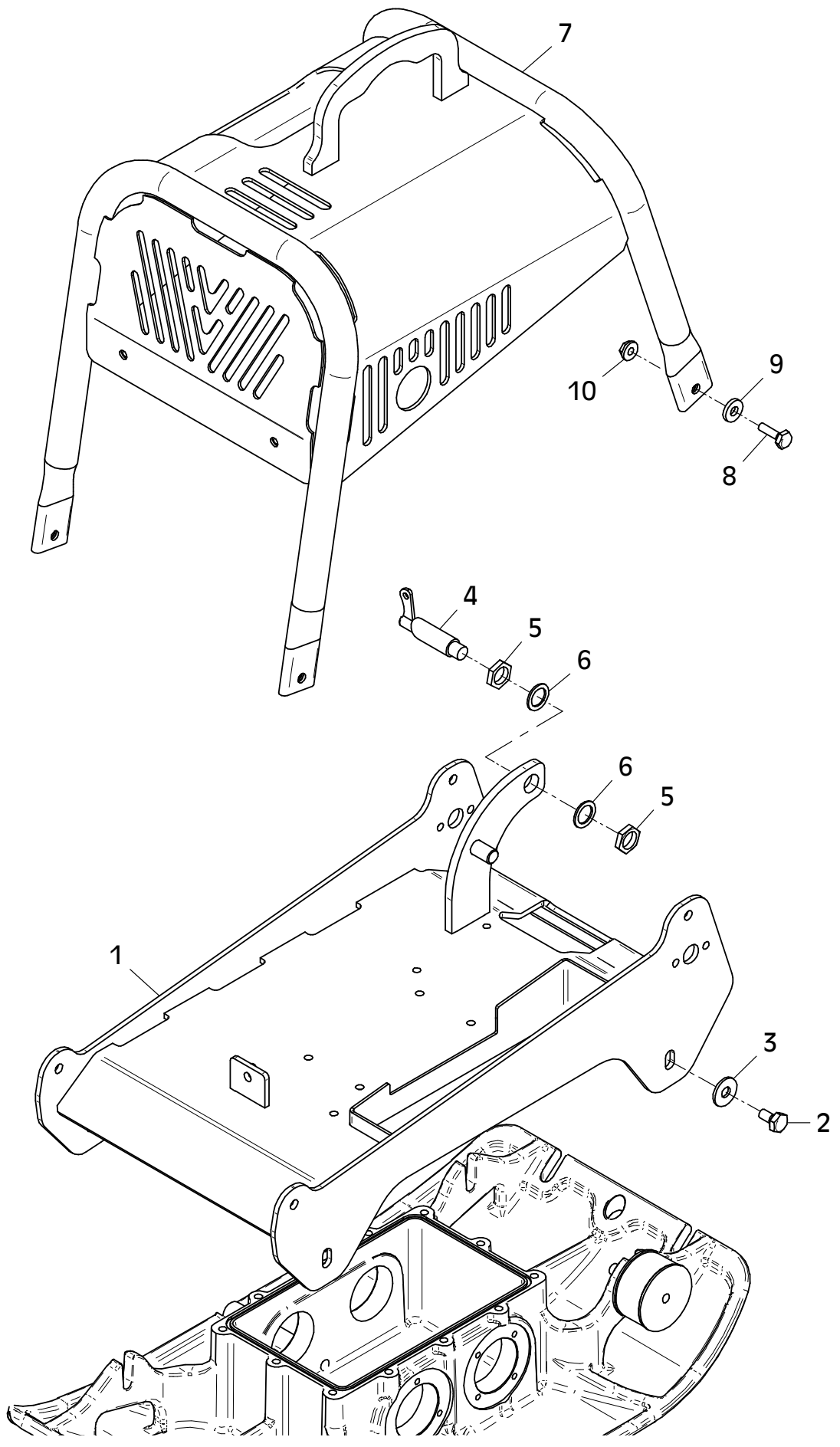

E 3652-0216

E 3653-0216

Position Ref.No. Repère Posizione Posicion	Menge Quantity Quantité Quantita Cantidad	Teile-Nr. Part-No. No. Référence Nr. d'Ordine No. Referenzia	Hinweis Hints Indications Indicazione Indicaciones	Position Ref. No. Repère Posizione Posicion	Menge Quantity Quantité Quantita Cantidad	Teile-Nr. Part-No. No. Référence Nr. d'Ordine No. Referenzia	Hinweis Hints Indications Indicazione Indicaciones
1	1	21000327					
1	1	21000345	EPA				
2	4	25038008	DIN933-M8x25				
3	4	20025122	VS 8				
4	4	20029024	Nord-Lock 8,0				
5	4	25031003	DIN934-M8				
6	1	11001954					
7	1	20007086					
8	2	25031002	DIN934-M6				
9	2	25048001	DIN125-A6,4				
10	1	20025060					
11	1	40031336					
12	1	40031334					
13	1	20025359					
13	1	11000868	EPA				
14	1	21001024	EPA				
15	1	21001025	EPA				

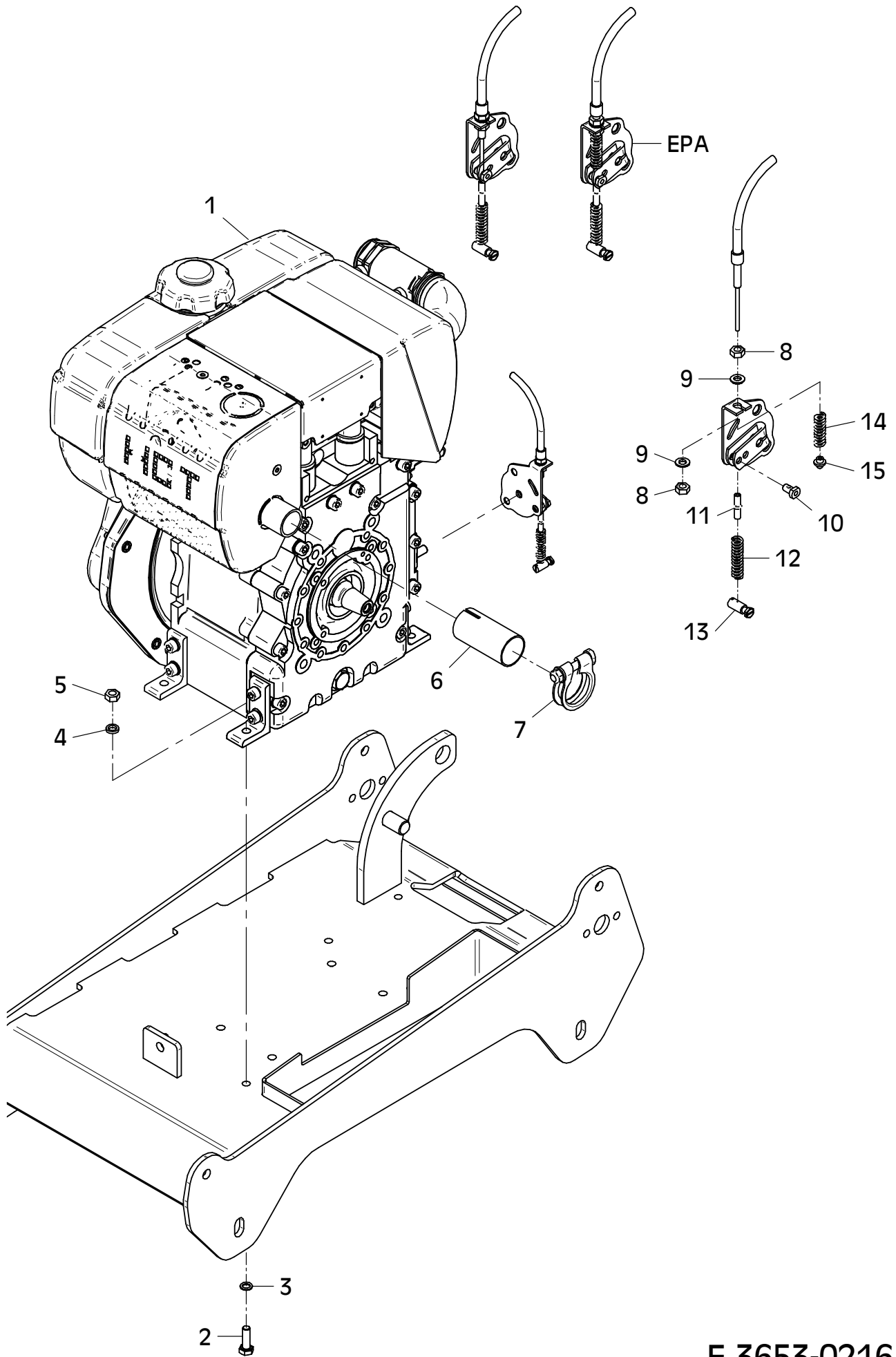

E 3653-0216

E 3668-0216

Position Ref.No. Repère Posizione Posicion	Menge Quantity Quantité Quantita Cantidad	Teile-Nr. Part-No. No. Référence Nr. d'Ordine No. Referenzia	Hinweis Hints Indications Indicazione Indicaciones	Position Ref. No. Repère Posizione Posicion	Menge Quantity Quantité Quantita Cantidad	Teile-Nr. Part-No. No. Référence Nr. d'Ordine No. Referenzia	Hinweis Hints Indications Indicazione Indicaciones
1	1	11001746					
2	4	20022013	Tensilock M10x20				
3	1	21001006					
4	1	21001020					
5	1	25044008	DIN912-M8x40				
6	1	20029003	VSK 8				
7	1	11002021					
8	1	11001838					
9	4	21000585	DIN7964-M8x40				
10	4	20029031	SKM 8				
11	1	21000518					
12	1	21000334					
13	1	25008017	DIN7603-22x27x1,5				
14	1	20007007					
15	1	25038003	DIN933-M6x20				
16	1	25048001	DIN125-A6,4				
17	1	20029007	VSK 6				
18	1	25031002	DIN934-M6				

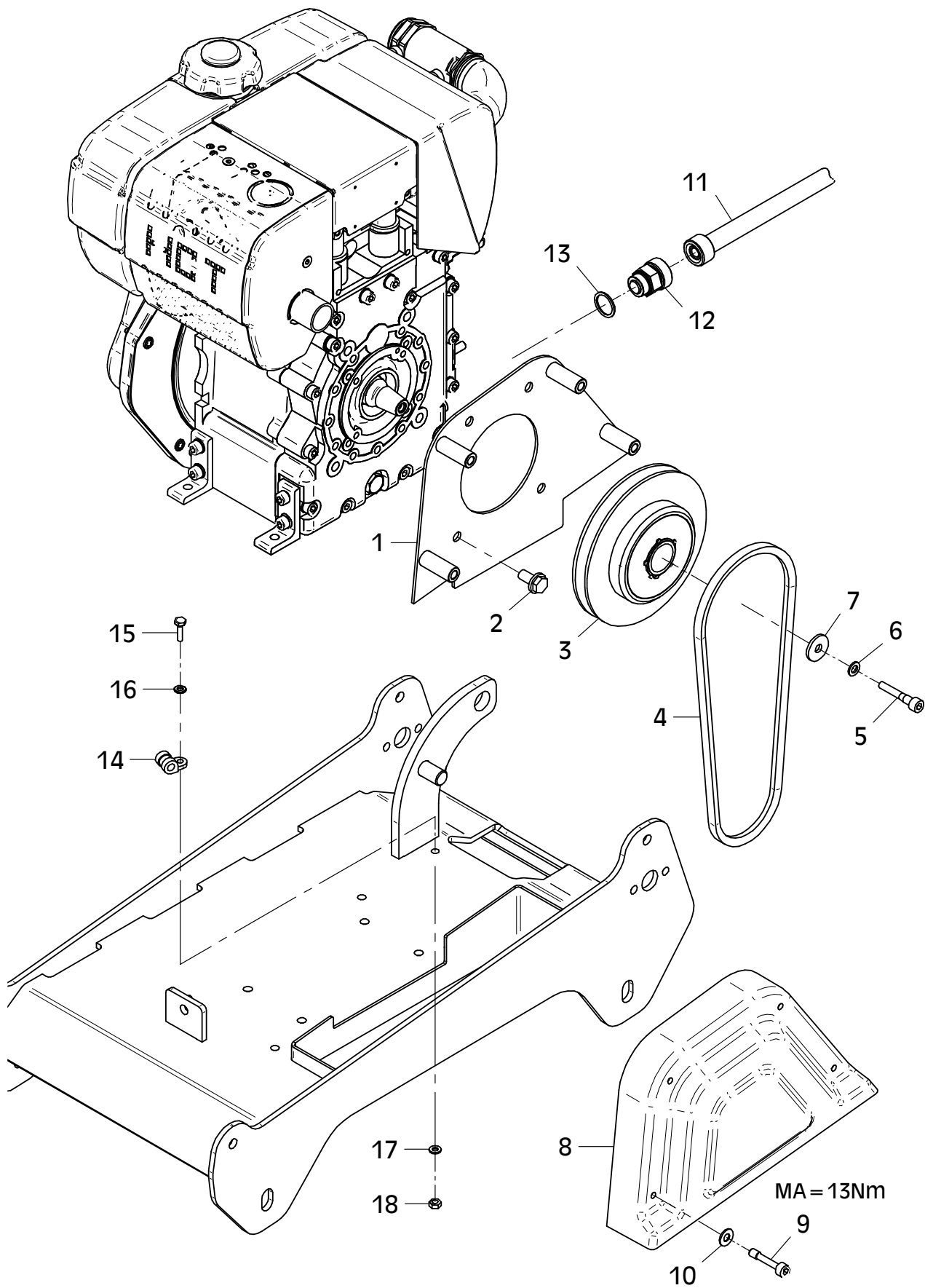

E 3668-0216

E 3665-0216

Position Ref.No. Repère Posizione Posicion	Menge Quantity Quantité Quantita Cantidad	Teile-Nr. Part-No. No. Référence Nr. d'Ordine No. Referenzia	Hinweis Hints Indications Indicazione Indicaciones	Position Ref. No. Repère Posizione Posicion	Menge Quantity Quantité Quantita Cantidad	Teile-Nr. Part-No. No. Référence Nr. d'Ordine No. Referenzia	Hinweis Hints Indications Indicazione Indicaciones
1	1	21001006					
2	2	20002222					
3	4	20002232					
4	2	20002221					

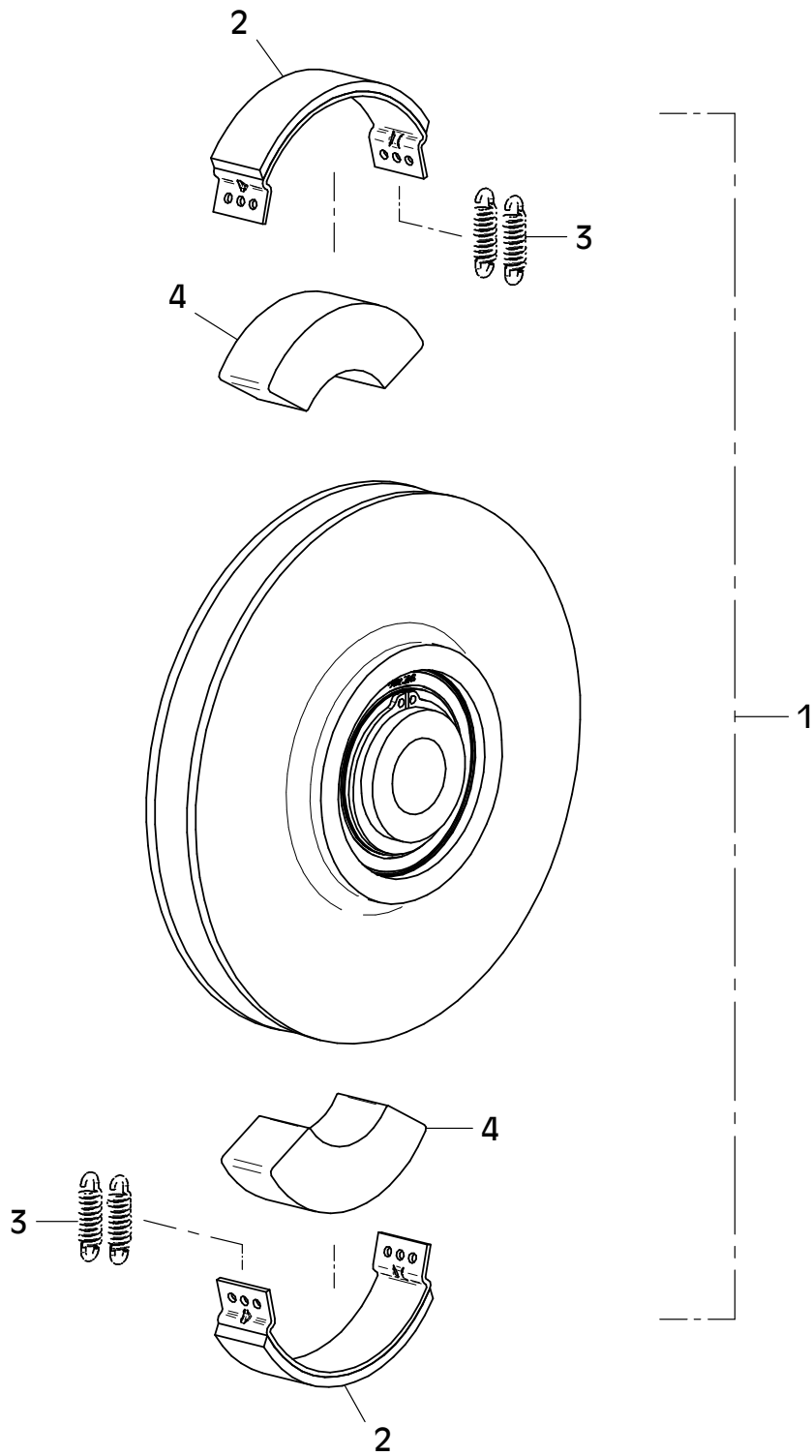

E 3665-0216

E 3965-0422

Position Ref.No. Repère Posizione Posicion	Menge Quantity Quantité Quantita Cantidad	Teile-Nr. Part-No. No. Référence Nr. d'Ordine No. Referenzia	Hinweis Hints Indications Indicazione Indicaciones	Position Ref. No. Repère Posizione Posicion	Menge Quantity Quantité Quantita Cantidad	Teile-Nr. Part-No. No. Référence Nr. d'Ordine No. Referenzia	Hinweis Hints Indications Indicazione Indicaciones
1	1	11002784					
2	1	21001097					
3	2	25025191	DIN80705-M20x1,5				
4	2	20025019	VS 20				
5	1	11002022					
6	0	11002850	t=1				
7	0	11002786	t=2				
8	1	11000567					
9	2	25031004	DIN934-M10				
10	2	20005019					
11	2	11002698					
12	2	21001770	DIN912-M16x25				
13	2	20029014	VSKZ 16				
14	2	11002687					
15	2	21001002	DIN912-M16x45				
16	1	20007202					
17	1	25031006	DIN934-M16				
				100		60002184	Loctite 243
						CR 2	ab Serien-Nr. 20073466
						CR 2 Hd	ab Serien-Nr. 20073472

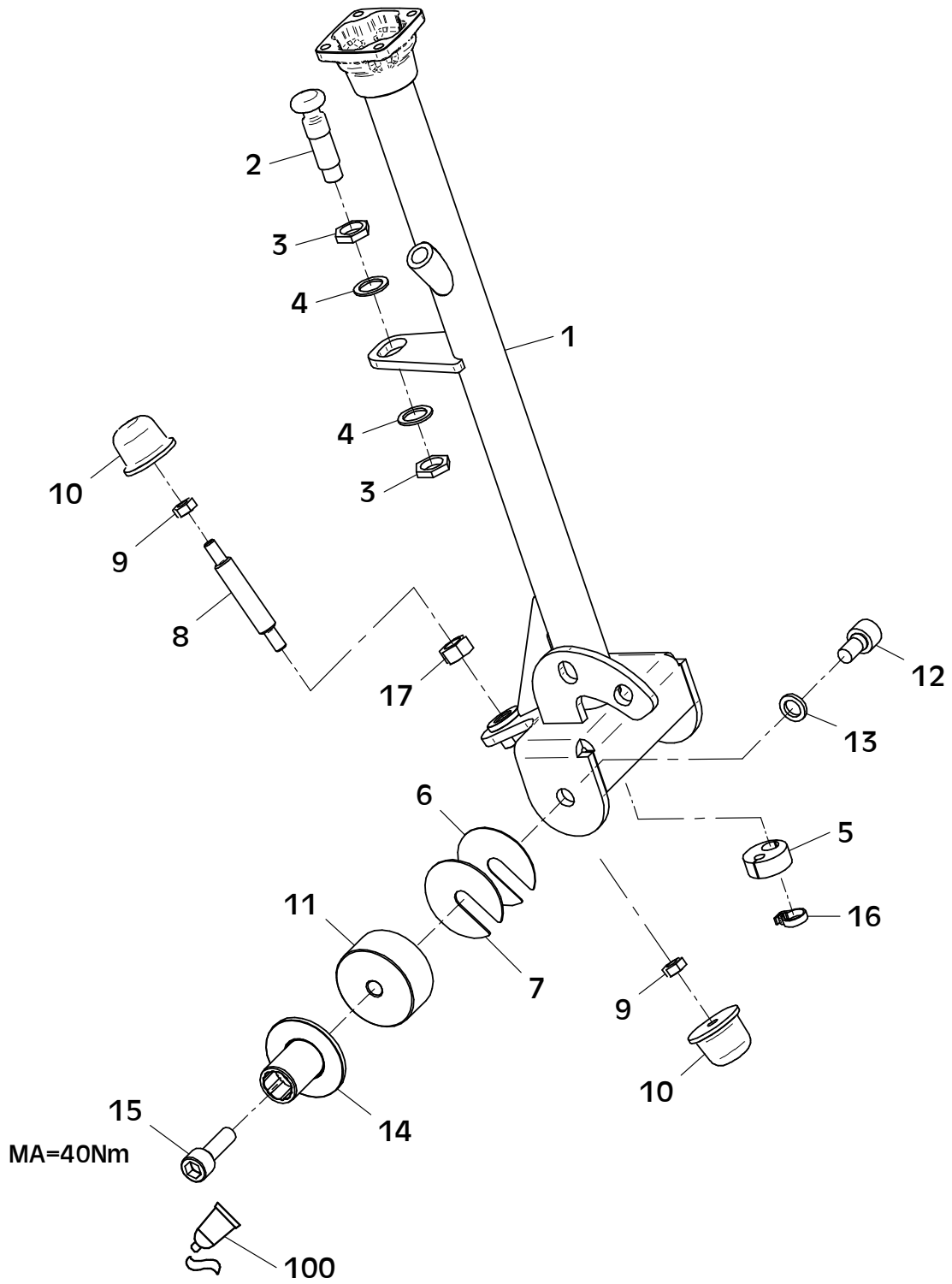

E 3965-0422

E 3966-0422

Position Ref.No. Repère Posizione Posicion	Menge Quantity Quantité Quantita Cantidad	Teile-Nr. Part-No. No. Référence Nr. d'Ordine No. Referenzia	Hinweis Hints Indications Indicazione Indicaciones	Position Ref. No. Repère Posizione Posicion	Menge Quantity Quantité Quantita Cantidad	Teile-Nr. Part-No. No. Référence Nr. d'Ordine No. Referenzia	Hinweis Hints Indications Indicazione Indicaciones
1	1	11001751					
2	2	21001012					
3	2	11002697					
4	4	25038007	DIN933-M8x20				
5	4	20029003	VSK 8				
6	2	21000869					
7	2	20008088					
8	1	20005012					
9	1	25031013	DIN985-M8				
10	1	11001967					
11	2	25040038	DIN931-M6x35				
12	2	20029007	VSK 6				
13	2	25049034	DIN7349-6,4				
14	2	25031012	DIN985-M6				
						CR 2	ab Serien-Nr. 20073466
						CR 2 Hd	ab Serien-Nr. 20073472

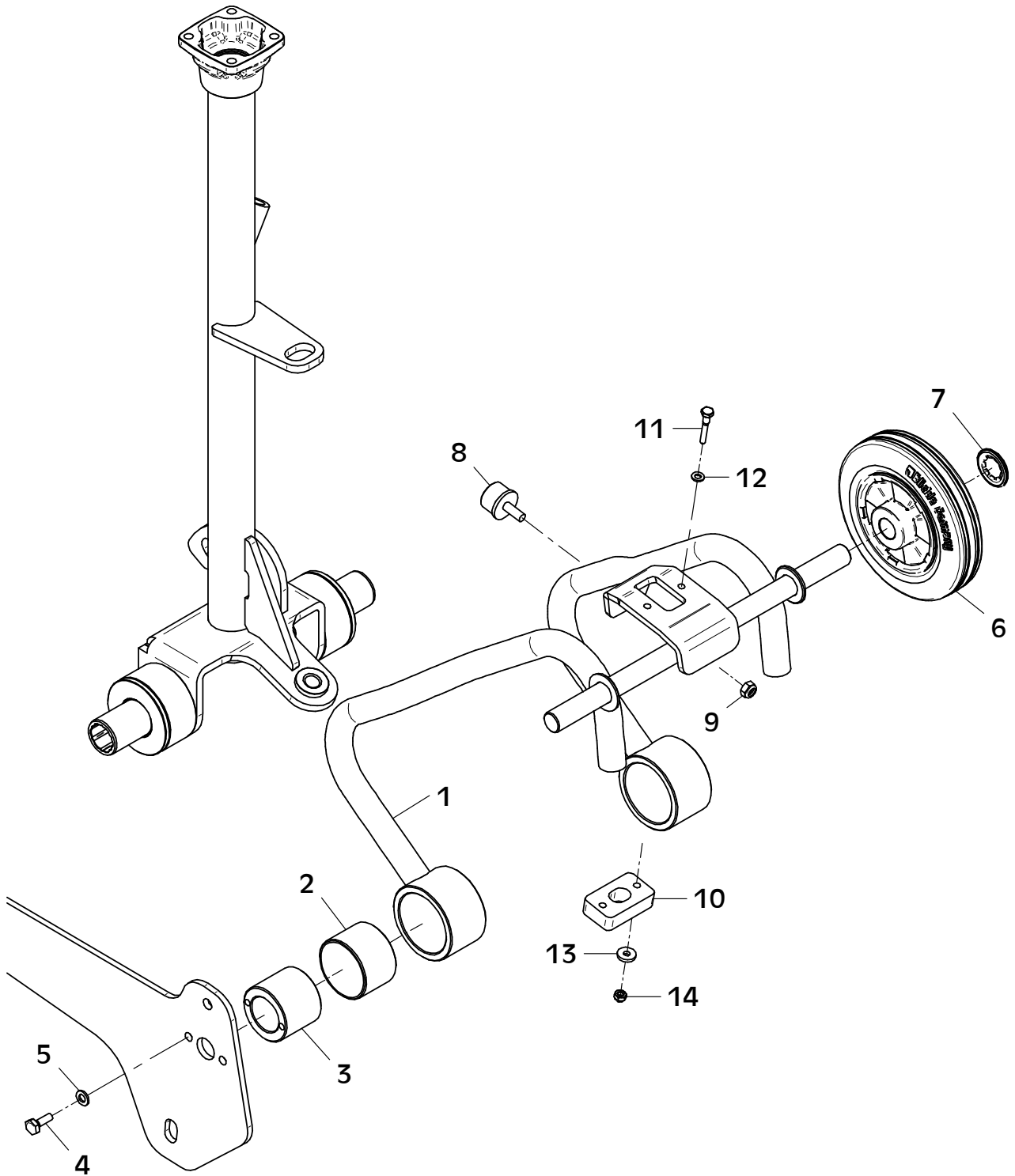

E 3966-0422

E 3655-0421

Position Ref.No. Repère Posizione	Menge Quantity Quantité Cantidad	Teile-Nr. Part-No. No. Référence Nr. d'Ordine No. Referenzia	Hinweis Hints Indications Indicazione Indicaciones	Position Ref. No. Repère Posizione	Menge Quantity Quantité Cantidad	Teile-Nr. Part-No. No. Référence Nr. d'Ordine No. Referenzia	Hinweis Hints Indications Indicazione Indicaciones
1	1	11001837					
2	4	25044006	DIN912-M8x25				
3	4	20029003	VSK 8				
4	1	25030003	DIN908-M24x1,5				
5	1	21000792	DIN7603-24x29x2				
6	1	21000256					
7	1	11001571					
8	1	11001570					
9	1	20013282					
10	1	21001004					
11	1	11001566					
12	1	21000997					
13	1	25035027	DIN472-J58x2,0				
14	1	20020035					
15	1	21001029					
16	1	21001022					
17	1	11001577					
18	2	21000734	DIN912-M5x12				
19	2	20029006	VSK 5				
20	1	11002286					
21	2	25044076	DIN912-M5x16				
22	2	20029006	VSK 5				
23	3	25048017	DIN125-A5,3				
24	1	25031023	DIN985-M5				
25	1	21001359					
26	1	11002024					
27	1	11002358					

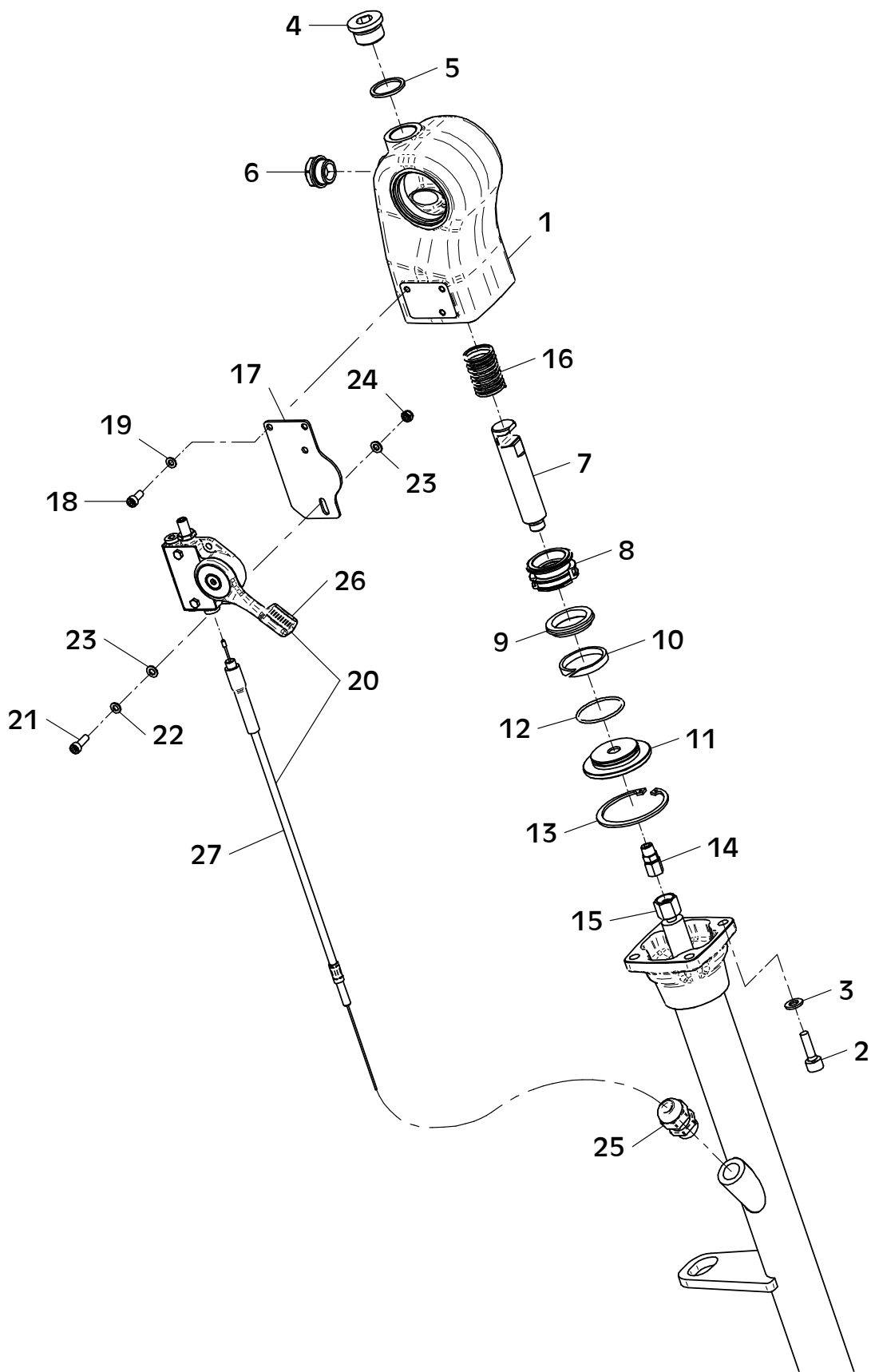

E 3655-0421

E 3659-0216

Position Ref.No. Repère Posizione Posicion	Menge Quantity Quantité Quantita Cantidad	Teile-Nr. Part-No. No. Référence Nr. d'Ordine No. Referenzia	Hinweis Hints Indications Indicazione Indicaciones	Position Ref. No. Repère Posizione Posicion	Menge Quantity Quantité Quantita Cantidad	Teile-Nr. Part-No. No. Référence Nr. d'Ordine No. Referenzia	Hinweis Hints Indications Indicazione Indicaciones
1	1	11001837					
2	4	25044006	DIN912-M8x25				
3	4	20029003	VSK 8				
4	1	25030003	DIN908-M24x1,5				
5	1	21000792	DIN7603-24x29x2				
6	1	21000256					
7	1	11001571					
8	1	11001570					
9	1	20013282					
10	1	21001004					
11	1	11001566					
12	1	21000997					
13	1	25035027	DIN472-J58x2,0				
14	1	20020035					
15	1	21001029					
16	1	11001972					
17							
18	1	21001017					
19	2	25044056	DIN912-M5x30				
20	2	21000952	SKM 5				
21	2	20022005	Tensilock M5				
22	1	25009021					
23	1	21001022					

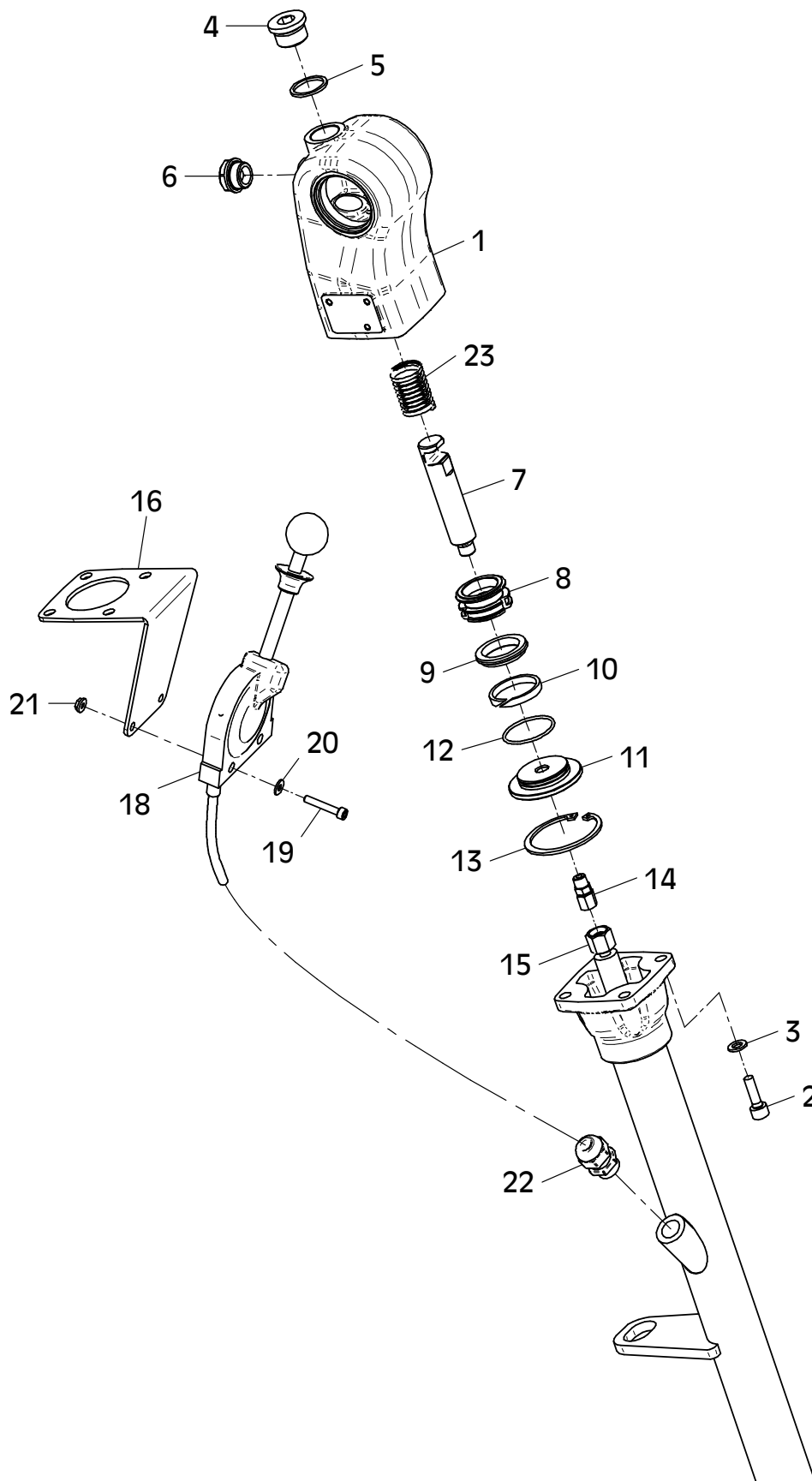

E 3656-0216

Position Ref.No. Repère Posizione Posicion	Menge Quantity Quantité Quantita Cantidad	Teile-Nr. Part-No. No. Référence Nr. d'Ordine No. Referenzia	Hinweis Hints Indications Indicazione Indicaciones	Position Ref. No. Repère Posizione Posicion	Menge Quantity Quantité Quantita Cantidad	Teile-Nr. Part-No. No. Référence Nr. d'Ordine No. Referenzia	Hinweis Hints Indications Indicazione Indicaciones
1	1	11001568					
2	2	11001567					
3	1	25034016	DIN471-A25x1,20				
4	2	11001569					
5	2	20025097					
6	2	21001005					
7	2	10017396					
8	2	25044053	DIN912-M12x20				
9	2	20025158	VS 12				
10	1	11001749					
11	4	25038006	DIN933-M8x16				
12	4	20029003	VSK 8				
13	2	20025594					
14	1	21000228	DIN6885-8x7x20				

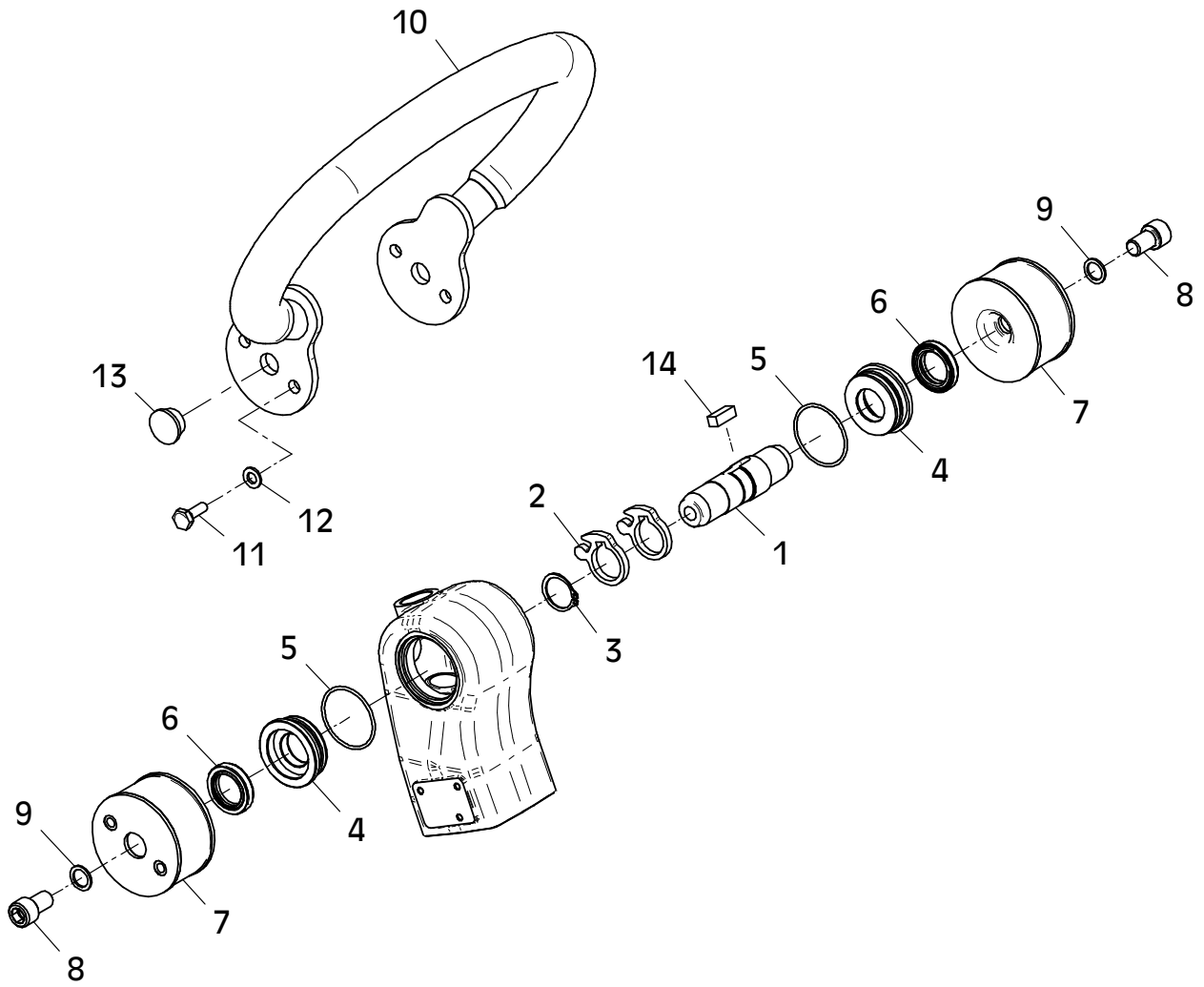

E 3656-0216

E 3657-0220

Position Ref.No. Repère Posizione Posicion	Menge Quantity Quantité Quantita Cantidad	Teile-Nr. Part-No. No. Référence Nr. d'Ordine No. Referenzia	Hinweis Hints Indications Indicazione Indicaciones	Position Ref. No. Repère Posizione Posicion	Menge Quantity Quantité Quantita Cantidad	Teile-Nr. Part-No. No. Référence Nr. d'Ordine No. Referenzia	Hinweis Hints Indications Indicazione Indicaciones
1	1	21000937					
2	1	11002184					
3	3	25044095	DIN912-M8x90				
4	3	25048002	DIN125-A8,4				
5	3	25049026	DIN7349-8,4				
6	1	21001048					
7	1	20030015					
8	1	21001596					
9	1	21001098	0,25m				
10	2	20007054					
11	1	11001576					
11	1	11002809	CR 2/55				
12	2	25030002	DIN908-M14x1,5				
13	2	25040032	DIN931-M12x45				
13	4	25040032	DIN931-M12x45 - CR 2/55				
14	2	25049006	DIN440-R14				
14	4	25049006	DIN440-R14 - CR 2/55				
15	2	25049040	DIN1441-13x25x3				
15	4	25049040	DIN1441-13x25x3 - CR 2/55				
16	2	25031005	DIN934-M12				
16	4	25031005	DIN934-M12 - CR 2/55				
17	1	20022002	Tensilock M8				
18	1	20025298					
19	1	21001340	DIN7976-8x22				
20	1	20029021	SKB 8				
21	1	21000307					
22	1	20030016					
23	1	20030072					
				100			Loctite 577
				200			Loctite 586

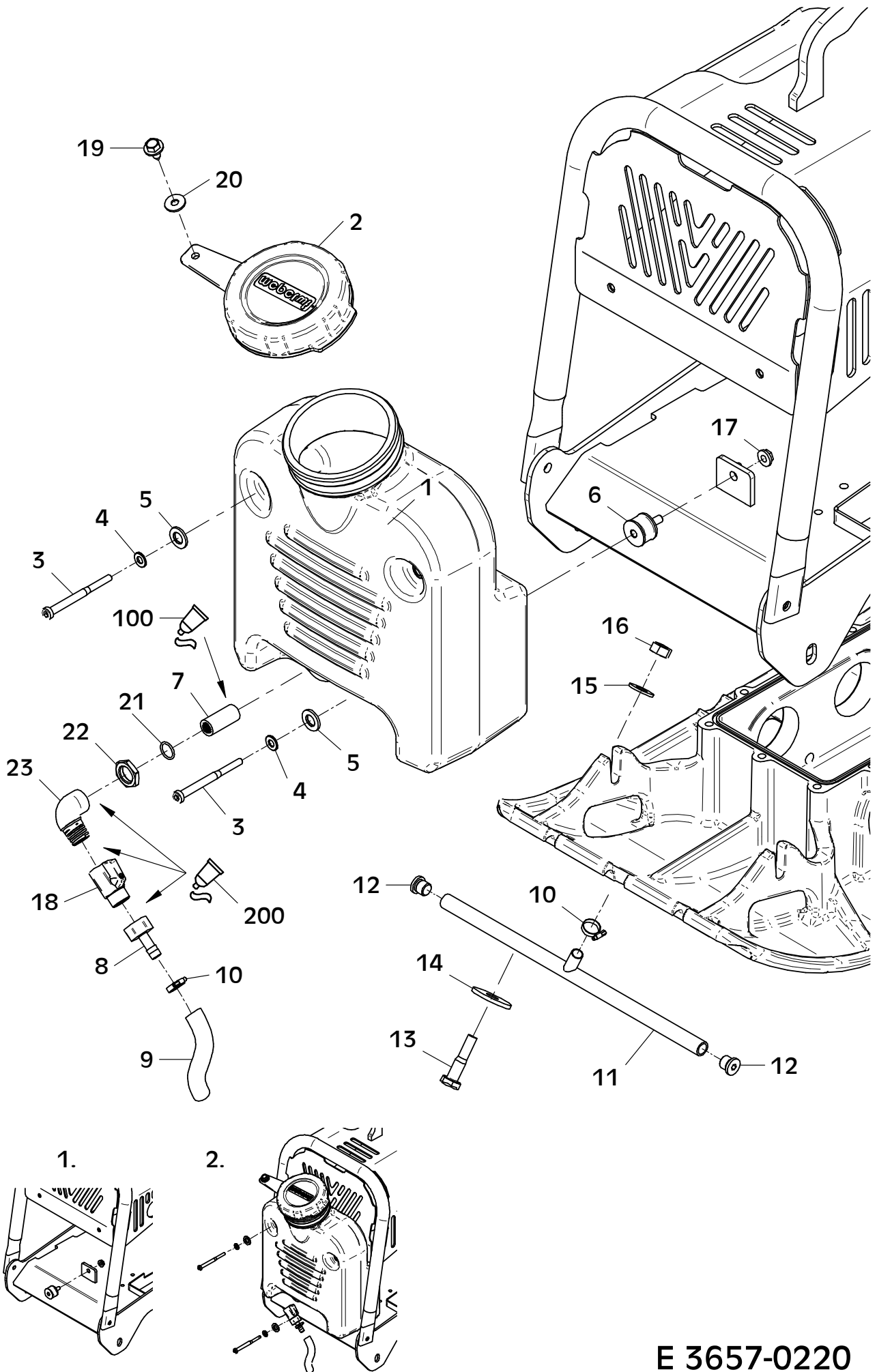

E 3657-0220

E 3667-0216

Position Ref.No. Repère Posizione Posicion	Menge Quantity Quantité Quantita Cantidad	Teile-Nr. Part-No. No. Référence Nr. d'Ordine No. Referenzia	Hinweis Hints Indications Indicazione Indicaciones	Position Ref. No. Repère Posizione Posicion	Menge Quantity Quantité Quantita Cantidad	Teile-Nr. Part-No. No. Référence Nr. d'Ordine No. Referenzia	Hinweis Hints Indications Indicazione Indicaciones
1	1	11001910					
1	1	11002776	CR 2/55				
2	2	11001968					
3	4	25040018	DIN931-M12x50				
4	4	25049040	DIN1441-13x25x3				
5	4	20029004	VSK 12				
6	4	25031005	DIN934-M12				

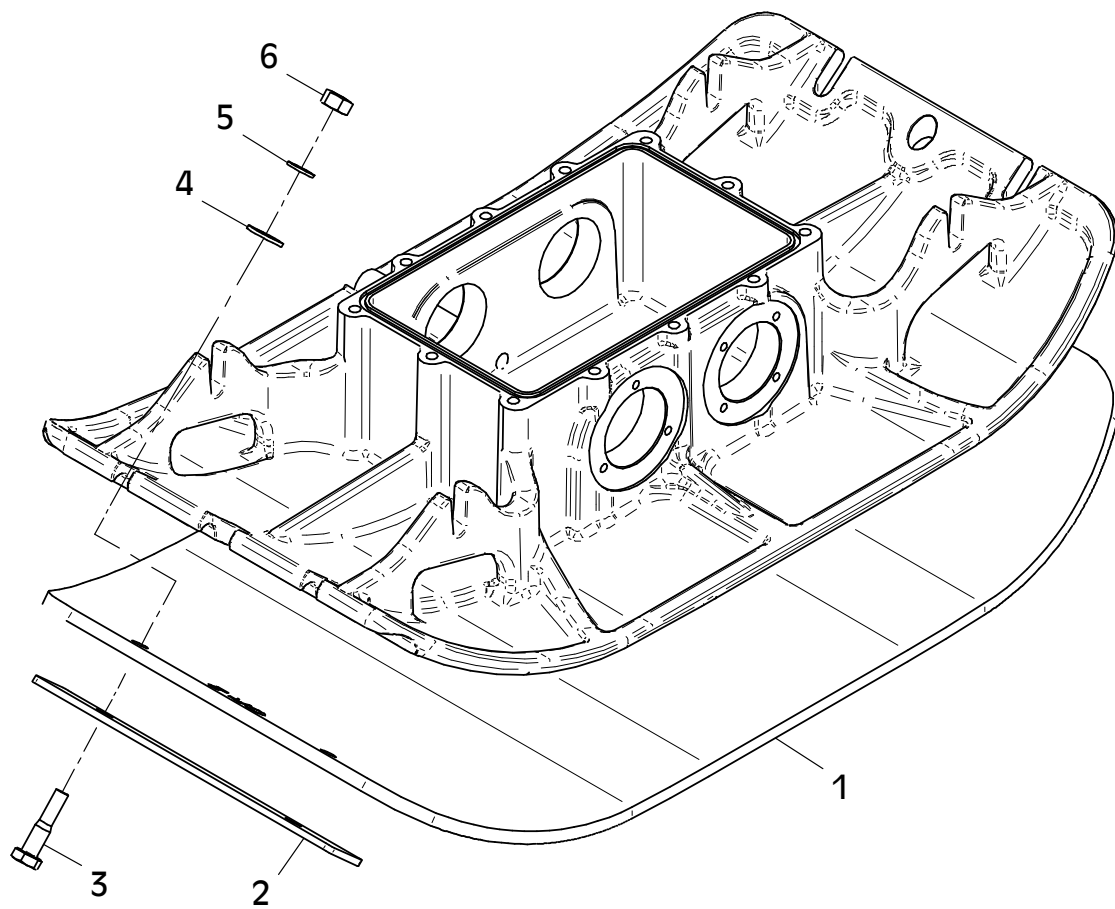

E 3667-0216

E 3866-1220

Position Ref.No. Repère Posizione Posicion	Menge Quantity Quantité Quantita Cantidad	Teile-Nr. Part-No. No. Référence Nr. d'Ordine No. Referenzia	Hinweis Hints Indications Indicazione Indicaciones	Position Ref. No. Repère Posizione Posicion	Menge Quantity Quantité Quantita Cantidad	Teile-Nr. Part-No. No. Référence Nr. d'Ordine No. Referenzia	Hinweis Hints Indications Indicazione Indicaciones
1	1	20019006					
2	1	21001160					
3	1	20019281					
4	1	41001436					
5	1	41001438					

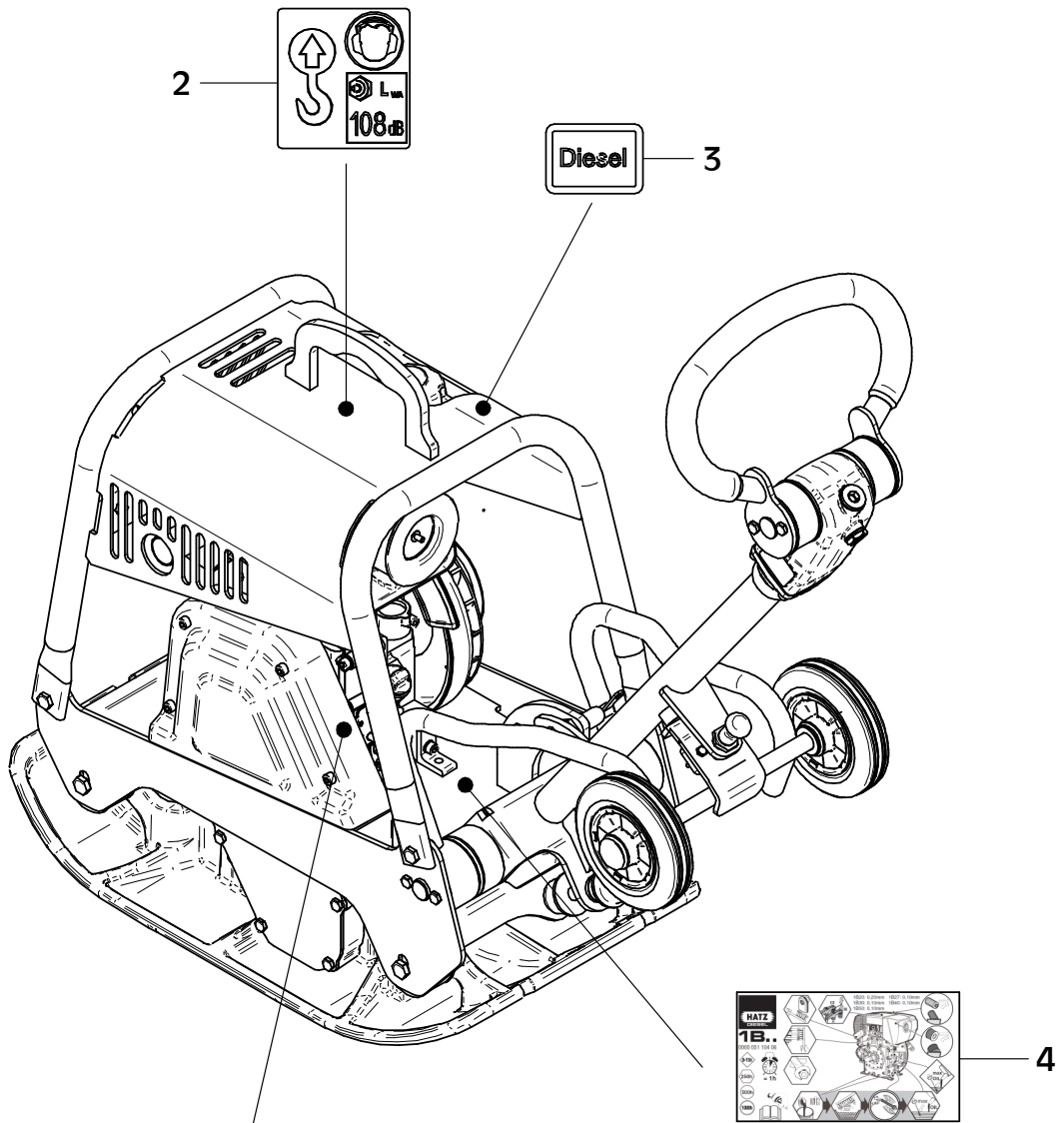

Alle Schraubenverbindungen ständig auf festen Sitz überwachen!
 -Besonders nach dem ersten Einsatz-

Continuously check all screwed connections for firm seating
 -particularly after initial employment-

Controler continuellement tous les raccords a vis pour un siege ferme
 -particulierement apres l'emploi initial-

1



5



facebook.com/WeberMT



youtube.com/MyWeberMT



Weber Maschinentechnik GmbH

Im Boden 5-8, 10 · 57334 Bad Laasphe · Deutschland

Telefon +49 2754 398 0 · Fax +49 2754 398 101

info@webermt.de · www.webermt.de

085201052 / CR 2_2022-05