

# Operating and Maintenance Manual



## CR 4 i

Yanmar L 70



**Weber Maschinentechnik GmbH**

Im Boden 5 - 8, 10

57334 Bad Laasphe-Rückershausen / Germany

Telephone +49 (0) 27 54 / 398-0

Fax +49 (0) 27 54 / 398-101

E-Mail: [info@webermt.de](mailto:info@webermt.de)

Web: [www.webermt.de](http://www.webermt.de)



## Table of contents

Introduction	4
Safety guidelines	5
Graphic presentation	8
Device description	9
Technical data	10
Activities prior to starting work	12
Starting	13
Driving and compacting	14
Shutting down	14
Maintenance overview	15
Maintenance work	16
Operating fluids and fill levels	19
Troubleshooting	19
Storage	20
Contact addresses	23

## **Introduction**

This operating and maintenance manual is designed to facilitate familiarization with your soil compactor, and to enable you to maintain the compactor and use it for its intended purpose. When complying with the instructions in the operating and maintenance manual you help avoid hazards, reduce repair and downtime costs, and increase the reliability and service life of your compactor.

This operating and maintenance manual must always be available at the implementation site of the soil compactor.

If necessary you can obtain additional information from your authorized WEBER dealer, or you can obtain information from one of the contact addresses on the last page.

The valid conformity declaration is enclosed with every machine delivery.

You can obtain information on the assembled Yanmar diesel engine at **[www.yanmarindustrial.eu](http://www.yanmarindustrial.eu)**.

## Safety guidelines

### General

All safety instructions must be read and complied with, non-compliance results in

- Danger to life and limb of the user
- Impairments to the machine or other property.

In addition to the operating manual, the accident-prevention regulations in the country where the appliance is used must be complied with.

### Intended use

The soil compactor should only be used if it is in a technically faultless condition, as intended, in a safety-conscious and hazard-conscious manner, in compliance with the instructions in the operating manual. Malfunctions that impair safety must be eliminated without delay.

The CR 4 soil compactor is designed exclusively for compacting

- sand
- gravel
- crushed rock
- semi-cohesive mixed material
- concrete paving stone.

Any other use of the soil compactor is considered to be improper use for which the owner shall be exclusively responsible. All liability is rejected if damage occurs due to non-compliance with this provision. This risk is borne solely by the user.

### Easily foreseeable misuse

Any use for which the machine is not intended.

### Operation

Soil compactors are only permitted to be operated by suitable persons of or above the age of eighteen. Personnel must be instructed in how to guide the compactor by the owner or by the owner's assigned personnel.

The machine operator must comply with traffic regulations. If instructions that affect safety are given by third parties, then the operator must be authorized to reject these instructions.



Unauthorized persons are forbidden from being in the area of the soil compactor during the compacting process.

### Protective equipment

This machine is capable of exceeding the permissible sound level of 80 dB(A). The owner might also face additional dangers when using the machine. Precautionary action must, therefore, be taken.

Protective equipment includes:



Hearing protection



Hard hat



Safety shoes



Protective gloves

## Operation

Prior to starting work the owner of the compactor must be familiar with the work environment. The work environment includes obstacles in the work and traffic area, the bearing capacity of the ground, as well as the necessary safeguarding of the construction site in the area adjacent to public traffic; and it includes compliance with traffic regulations.

The soil compactor should only be operated when the protective fixtures are mounted. The protective fixtures must all be in functional condition.

At least once per shift the compactor must be checked for apparent defects. If there are apparent defects then operation of the compactor must be stopped immediately, and the responsible person must be informed. Prior to restarting, compactor malfunctions that have occurred must be corrected.

Always maintain adequate clearance to the edges of pits and embankments.

Do not drive at ninety degrees to slopes to prevent the compactor from tipping over.

After work has been concluded secure the compactor in accordance with statutory regulations, particularly in the area of public traffic surfaces.

## Operation under difficult conditions

 Never inhale the exhaust gas; it contains carbon monoxide, a colorless and odorless gas that is extremely hazardous, which, if inhaled even briefly, can cause unconsciousness and death.

Therefore, never operate the engines in enclosed areas or in areas that are poorly ventilated (tunnels, caves, etc.). Exercise particular caution when operating the engine in the vicinity of people and livestock.

## Maintenance and repair work

Only use **original Weber spare parts** to ensure reliable and safe operation for maintenance or repair work.

Hydraulic hose lines must be checked at regular intervals in accordance with standard engineering practice, or they must be replaced at appropriate intervals, even if no signs of safety-relevant defects are present.

Adjusting tasks, maintenance tasks, and inspection tasks must be carried out on schedule as specified in this operating and maintenance manual. These activities should only be executed by instructed personnel.

For repair, service, or inspection work the engine of the compactor must be safeguarded against unintentional starting.

All pressurized lines, particularly hydraulic lines and lines of the injection system of the drive motor must be depressurized before performing maintenance or repair tasks.

For maintenance and repair tasks the compactor must be parked on a level and stable substrate and must be secured from rolling off or tipping over.

Heavy components and assemblies must be secured to and lifted by hoisting machines that can bear their weight when they are replaced. Ensure that no hazard is caused by raising components or assemblies.

Do not position yourself or work under suspended loads.

 If lubricating oils and fuel come into contact with skin, they can cause skin cancer. Upon contact with the skin, clean affected skin with suitable cleaning agent without delay.

## Inspection

Compactors must be inspected in accordance with the corresponding implementation conditions and operating conditions, as needed; however an inspection to ensure operationally safe status must be performed by an expert at least once a year. The results of the inspection must be recorded in writing and must be stored at least until the next inspection.

## Cleaning work

Prior to cleaning the compactor with a high-pressure cleaner, protect all accessible energized switches, cable connections, etc. against water penetration by masking them off.

Cleaning tasks should only be executed in areas that are suitable and have been approved for this purpose (oil separator amongst others).

## Disposal

All operating fluids and auxiliary materials must be disposed of in an environmentally-compatible manner in accordance with country-specific regulations.

**Important information for operating and maintenance personnel is marked by pictograms.**



Warning against irritants or materials hazardous to health



Warning against a hazardous place



Warning against a suspended load



Wear ear protection



General regulation



Environmental protection



Hard hat



Safety shoes



Protective gloves

## Graphic presentation

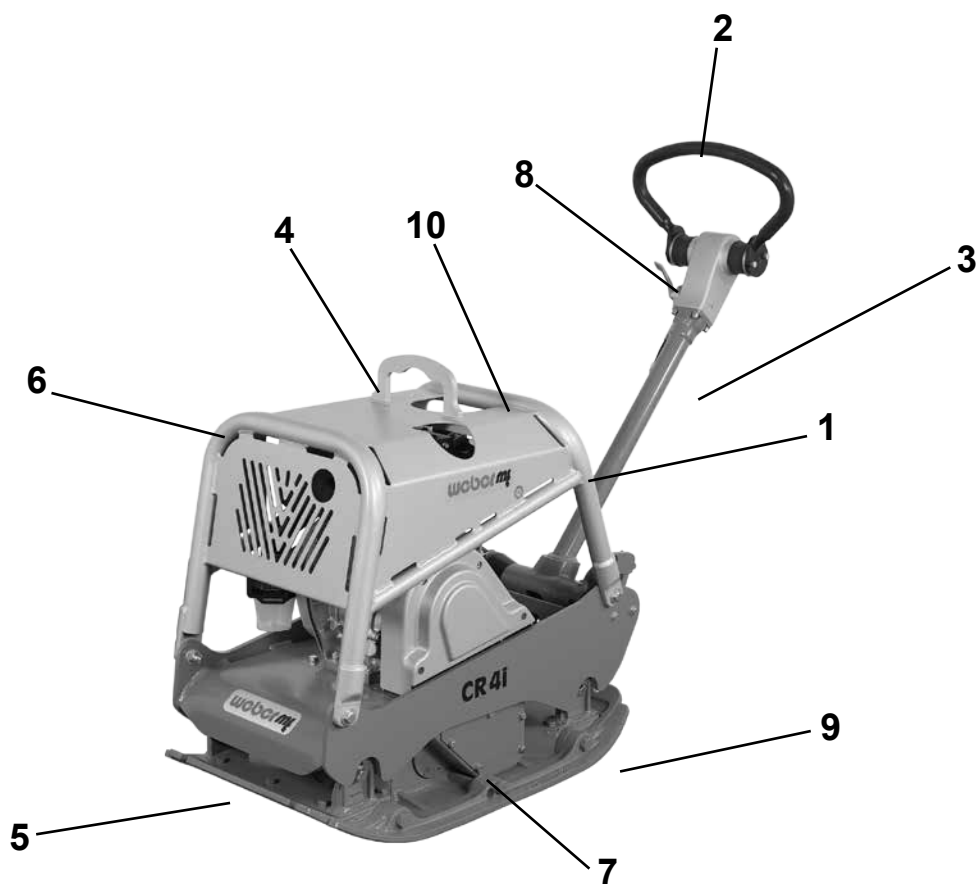

### Overall view CR 4

- 1 Engine
- 2 Drive lever
- 3 Manual guidance rod
- 4 Lifting ring
- 5 Base plate
- 6 Protective frame
- 7 Exciter
- 8 Gas lever
- 9 Attachment plates
- 10 Hearing protection (sticker)





## **Device description**

The CR 4 compactor is used for road-building and landscaping compaction tasks.

## **Drive**

The compactor is propelled by an air-cooled Yanmar diesel engine.

Force is transferred to the exciter mechanically via a V-belt.

## **Operation**

Start the Yanmar diesel engine with the attached reversing starter.

After starting, vibration is switched on via the centrifugal clutch attached to the engine.

Use the gas lever to vary the engine speed between idle and full throttle.

Forward and reverse is variably controlled via the handle attached to the manual guidance rod.

## Technical data

	<b>CR 4 i</b>
<b>Weight</b>	
Operating weight CECE in kg (basic device)	281
<b>Dimensions</b>	
Overall length (in mm)	1480
Overall width/with attachment plates (in mm)	550/700
Height with folded manual guidance rod (in mm)	1090
Base plate length (base in mm)	250
Pressure surface (in mm)	550x250
<b>Drive</b>	
Engine manufacturer	Yanmar
Type	L 70
Performance at operating speed in accordance with ISO 3046-1 (kW)	4.6
Combustion process	4-stroke diesel
Operating speed (m/min)	3300
Operating speed (ground-dependent in m/min)	20
Incline capacity (ground-dependent in %)	35
Area capacity/with attachment plates (in m <sup>2</sup> /h)	660/840
<b>Vibration</b>	
System	Two-wave vibrator
Drive concept	Mechanical
Frequency (in Hz)	75
Centrifugal force (in kN)	40

	<b>CR 4 i</b>
<b>Noise emissions in accordance with 2000/14/EC</b>	
Sound pressure level $L_{PA}$ ascertained in accordance with EN 500, in dB (A)	88
Sound power level $L_{WA}$ ascertained in accordance with EN ISO 3744 and EN 500, in dB (A)	108
<b>Vibration values</b>	
Root-mean-square acceleration value for hand-arm vibration ascertained in accordance with EN 500 in m/s <sup>2</sup>	3,6
 In accordance with directive 2006/42/EC, complying with the vibration values is the owner's responsibility.	

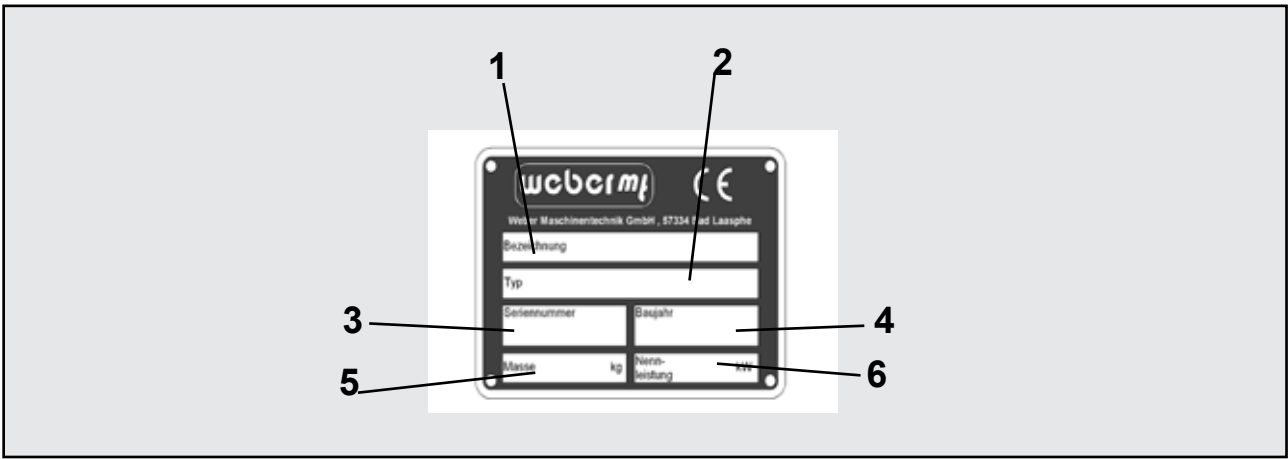

<p><b>1 Description</b></p> <p>.....</p>	<p><b>2 TYPE</b></p> <p>.....</p>
<p><b>3 Serial number</b></p> <p>.....</p>	<p><b>4 Year of construction</b></p> <p>.....</p>
<p><b>5 Mass</b></p> <p>.....</p>	<p><b>6 Rated power kW</b></p> <p>.....</p>

## Activities prior to starting work

### Transport

 When transporting the soil compactor on a vehicle, secure it with suitable restraints.

Arrest the manual guidance rod (1) with the spring bolt (2).

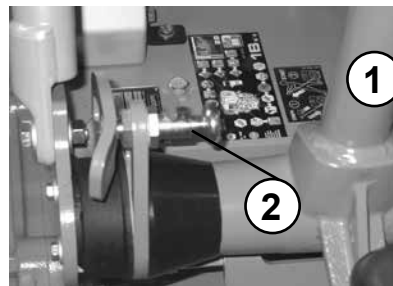

Fit the crane hook into the lifting ring (1) and lift the machine onto the desired means of transport.

 Only use lifting machines with a minimum bearing capacity of 350 kg.

 Do not step under suspended loads.



### Adjusting the manual guidance rod

Adjust the desired work height of the manual guidance rod with the set screw (1).

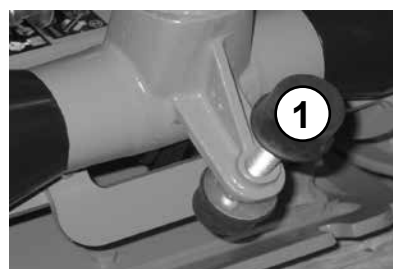

### Checking the engine oil level

Pull the oil dip stick (1) out of the crankcase.

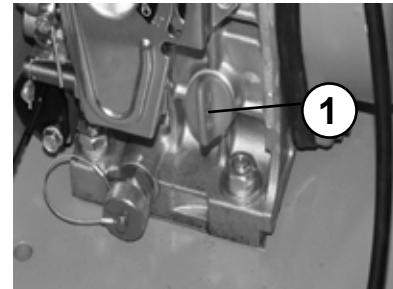

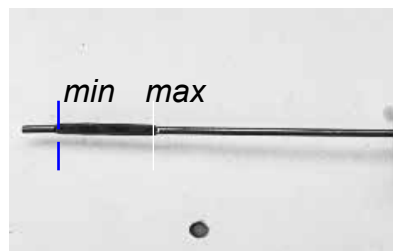

The correct oil level is between the min. and max. marks.



### Check the fuel level

Open and remove the gas cap (1), check the fill level, if necessary top off with clean diesel fuel to the lower edge of the filler neck.

 For work at the fuel system, have a suitable fire-extinguishing agent at the ready.

 Fire, naked light, and smoking is forbidden!

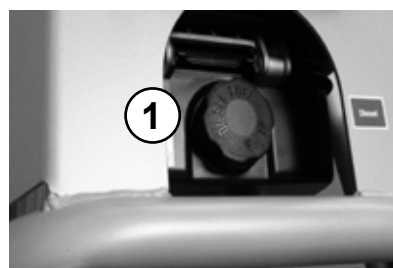

## Check the hydraulic oil level

Check the hydraulic oil level when the machine is at operating temperature. The correct oil level is reached when the oil is in the middle of the view glass.

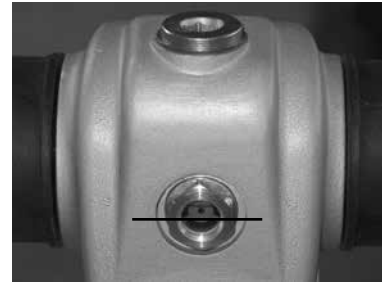

## Mounting the attachment plates

Tighten the screws (1) of the attachment plates (2) with a torque of 310 Nm.

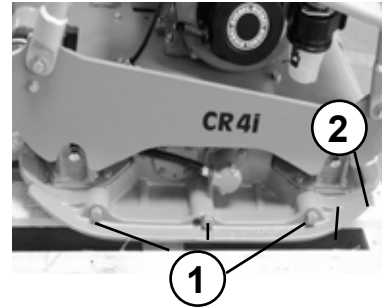

## Installing the protective mat

Fasten the protective mat with holder, screws, spring-lock washers and nuts on the base plate front and rear.

! Ensure that the protective mat rests under the base plate.



## Starting

Bring the gas lever into full-throttle position.

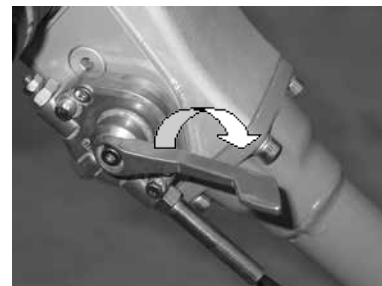

Open the fuel cock (1).

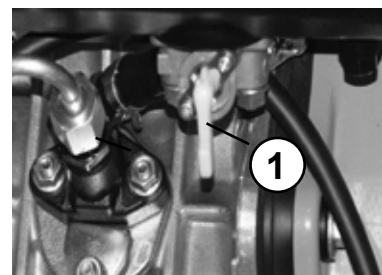

Slowly tighten the handle (1) of the reversing starter (2) until resistance is noticeable.

Allow the handle (1) to glide back into the initial position.

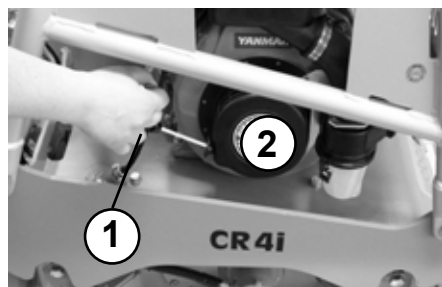

Push down the decompression lever (1) of the Yanmar diesel engine.

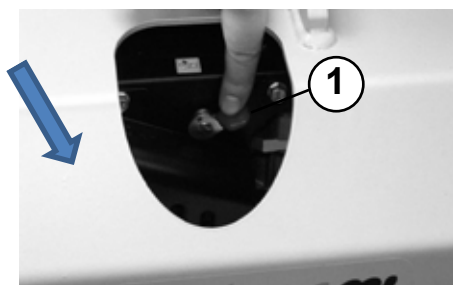

Completely pull through the starter.  
Allow the engine to warm up for a few minutes.



When starting in enclosed spaces ensure adequate ventilation – danger of suffocation.



If temperatures are below minus 5 degrees Celsius, comply with the instructions in the operating manual provided by the engine manufacturer.



Never use any starter spray.

## Compacting

Bring the gas lever (1) into full-throttle position.

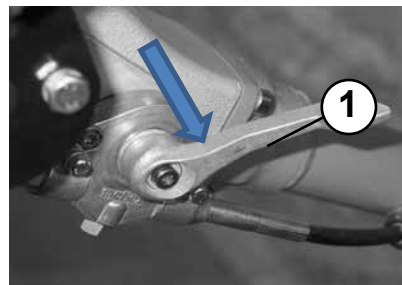

Control drive speed and direction of travel with the handle (1).

 Only run machine within reach of the manual guidance rod.

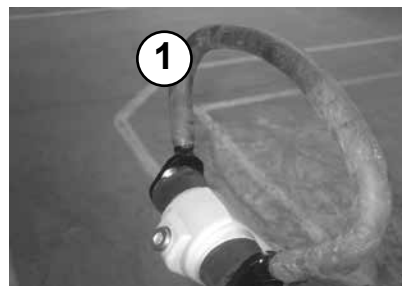

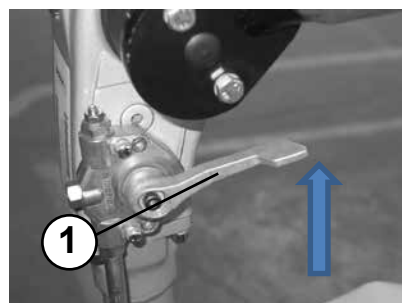

## Shutting down

Bring the gas lever (1) into idle position.



Close the fuel cock (1).





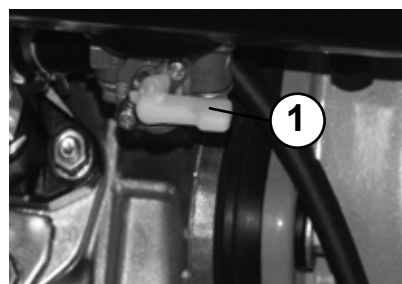

 During breaks – even if they are short – the machine must be shut down.

 Parked devices that represent an obstacle must be safeguarded against through conspicuous measures.



## Maintenance overview

Maintenance interval	Maintenance point	Maintenance activity
<b>After the first 25 operating hours</b>	Engine	<ul style="list-style-type: none"> <li>– Change the engine oil</li> <li>– Re-tighten all accessible threaded connections</li> </ul>
<b>Every 8 operating hours / daily</b>	Air filter	<ul style="list-style-type: none"> <li>– Clean air filter insert, check for damage, replace if necessary</li> </ul>
<b>Every 150 operating hours / every 6 months</b>	Engine	<ul style="list-style-type: none"> <li>– Change the engine oil</li> <li>– Change the fuel oil</li> <li>– Change the oil filter</li> </ul>
<b>Every 150 operating hours / every year</b>	Transmission  Exciter	<ul style="list-style-type: none"> <li>– Change oil</li> <li>– Change oil</li> </ul>

-  The regulations of the engine manufacturer must be complied with in addition to the above maintenance overview!
-  Work must be carried out using regulation tools, and the operating and maintenance manual must be complied with for all work.
-  All maintenance work: select a collection vessel that is large enough to prevent oil from spilling onto the ground. Dispose of waste oil in an environmentally friendly manner (regulation on waste oils).
-  Dispose of oils, greases, cloths soaked in oil, and replaced parts with oil on them in an environmentally friendly manner.
-  If lubricating oils and fuel come into contact with skin, they can cause skin cancer. Upon contact with the skin, clean affected skin with suitable cleaning agent without delay.
-  If accessible during maintenance, check the condition and stability of all screws.



## Maintenance work

### Change the engine oil

Open the screw cap (1) of the oil filler neck.

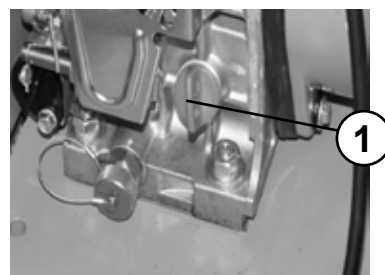

Screw the oil drain pipe (1) onto the engine drain valve and drain off the oil.

 Only drain engine oil when at operating temperature.

After emptying completely, unscrew the oil drain pipe from the drain valve and fill with oil in accordance with the specification.

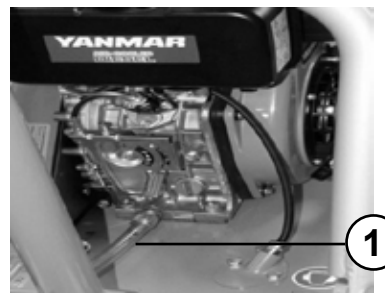

### Clean the engine oil filter

Drain engine oil.

Remove screw (2) and engine oil filter (1).

Wash out engine oil filter in gasoline

Screw in engine oil filter (1) and secure screw (2).

Top off engine oil in accordance with the specification.

Check engine oil level.

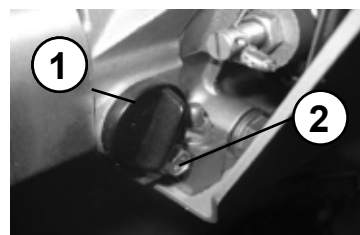

Dispose of oils, greases, cloths soaked in oil, and replaced parts with oil on them in an environmentally friendly manner.



If lubricating oils and fuel come into contact with skin, they can cause skin cancer. Upon contact with the skin, clean affected skin with suitable cleaning agent without delay.

## Change the fuel filter

Remove the gas cap (1).

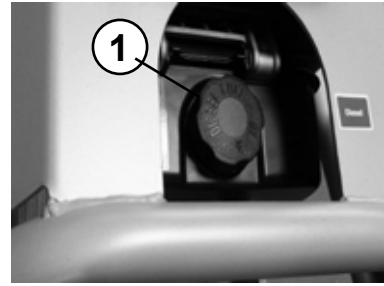

Remove the sieve (1) from the tank and clean sieve.



Unscrew the drain screw (1) from the tank and drain all diesel fuel from the tank.

Remove the fuel shut-off valve (2) from the tank by loosening both screws (3).

Pull the interior filter out through the tank opening (using long-nose pliers) and renew the filter.

Proceed in reverse order to refit the filter.

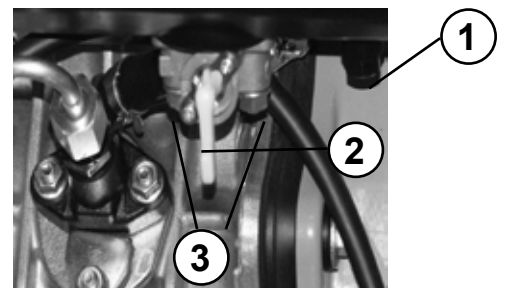

## Clean/change air filter cartridge

Unscrew the air filter cover (1).

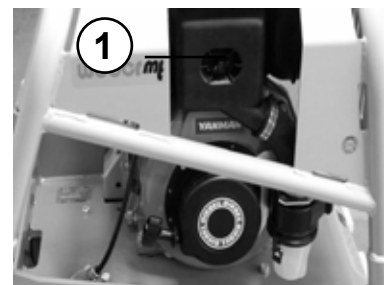

Remove the air filter insert (1) from the air filter enclosure. Clean air filter insert as specified by the engine manufacturer if there is damage or if it is extremely dirty.

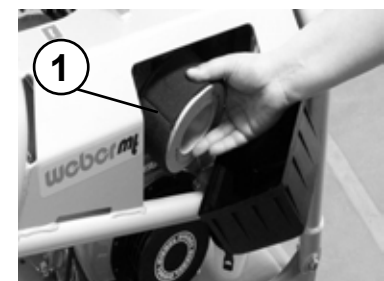

Take off, clean and refit the collection container (1).



Dispose of oils, greases, cloths soaked in oil, and replaced parts with oil on them in an environmentally friendly manner.



If lubricating oils and fuel come into contact with skin, they can cause skin cancer. Upon contact with the skin, clean affected skin with suitable cleaning agent without delay.

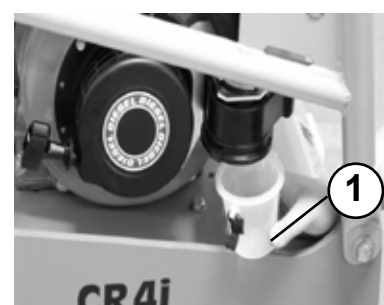

## Changing the oil in the exciter

Remove the oil drain screw (1) and drain oil.

To fill – tilt the machine slightly and fill with fresh oil through the drain opening in accordance with the fill level table.



Select a collection vessel that is large enough to prevent oil from spilling on the ground. Dispose of waste oil in an environmentally friendly manner (regulation on waste oils).

Wipe up/off oil slick and oil residue and dispose of fuel-soaked cleaning cloths in an environmentally responsible manner.

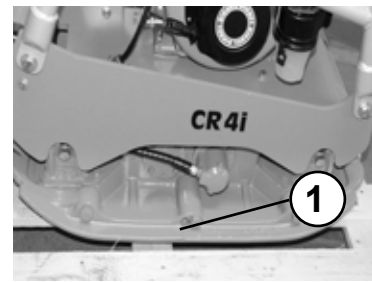

## Checking the V-belt

Remove the V-belt guard (1).



Check the V-belt (1) for cracks, damaged flanks, and wear.

If there is excessive wear – replace the V-belt as specified in the repair manual.

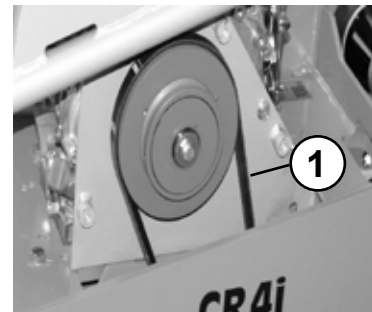

## Operating fluids and fill levels

Assembly	Operating material		Quantity
	Summer	Winter	CR 4 i
	<b>Quality</b>		
<b>Engine</b> Engine oil	SAE 10 W 40 (-10 ~ +50 °C) API – CD CE-CF-CG or SHPD or CCMC – D4 – D5 – PD2		1.1 l
<b>Fuel tank</b>	<b>Diesel</b> Diesel in accordance with DIN 51601-DK or BS2869-A1/A2 or STM D975-1D/2D		4.6 l
<b>Vibrator</b>	Fully-synthetic transmission fluid API GL-5/GL-4 First filling Fuchs Titan SINTOPOID LS SAE 75W-90		0.75 l
<b>Transmission</b>	Transmission fluid DEXRON II-D-ATF First filling Fuchs Titan ATF 3000 or equivalent		as necessary

## Troubleshooting

Fault	Possible cause	Remedy
<b>Soil compactor does not start</b>	Operating error	Execute start process as prescribed
	Lack of fuel	Check the fuel level
	Fuel filter fouled	Change the fuel filter
	Air filter fouled	Clean/change air filter cartridge
<b>No vibration /no forward motion or insufficient forward motion</b>	Vibrator V-belt defective	Change vibrator V-belt
<b>Soil compactor does not switch</b>	Wrong hydraulic oil level in the manual guidance rod	Check oil level Correct oil level

## Actions to be taken before long-term storage (longer than a month)

<b>Entire soil compactor</b>	<ul style="list-style-type: none"><li>– Clean thoroughly</li><li>– Check for leaks</li><li>– If there are leaks, correct defects</li></ul>
<b>Fuel tank</b>	<ul style="list-style-type: none"><li>– Empty fuel and fill with clean fuel up to the lower edge of filler neck</li></ul>
<b>Engine</b>	<ul style="list-style-type: none"><li>– Check oil level, if necessary fill to upper oil-level mark</li><li>– Check air filter, clean, replace if necessary</li><li>– Check fuel filter, change if necessary</li></ul>
<b>All bare parts / accelerator / accelerator control cable / fastening bolts</b>	<ul style="list-style-type: none"><li>– Oil / grease</li></ul>



If the machine is to be stored for longer than six months, then contact the Weber service organization to discuss additional measures.





## Weber Maschinentechnik GmbH

**For problems, questions and further information refer to one of the following addresses:**

in Germany	WEBER Maschinentechnik GmbH Im Boden 5 – 8, 10 57329 Bad Laasphe - Rückershausen	Telefon Telefax  E-Mail	+ 49 (0) 2754 - 398-0 + 49 (0) 2754 - 398101-switchboard + 49 (0) 2754 - 398102- spare parts- directlinie  g.voelkel@webermt.de
in France	WEBER Technologie SARL 14' rue d' Arsonval 69680 Chassieu	Telefon Telefax  E-Mail	+ 33 (0) 472 -791020 + 33 (0) 472 -791021  france@webermt.com
in Poland	WEBER Maschinentechnik Sp. zo.o. Ul. Jezioraki 86 02-863 Warszawa	Telefon Telefax  E-Mail	+ 48 (0) 22 - 739 70 - 80 + 48 (0) 22 - 739 70 - 81 + 48 (0) 22 - 739 70 – 82  info@webermt.com.pl
In Tschechien	WEBER MT s.r.o. V Piskovne 2054 278 01 Kralupy nad Vitavou	Telefon  E-Mail	+ 42 (0) 776 222 216 + 42 (0) 776 222 261  info@webermt.cz
in USA and Canada	WEBER MT 4717 Broadmoor Ave. SE Suite B Grand Rapids, MI 49512	Telefon Telefax  E-Mail	+ 1(207) - 947 - 4990 + 1(207) - 947 – 5452  sales@webermt.us service@webermt.us

**> Vibration plates**

**> Vibrating tampers**

**> Vibration rollers**

**> Joint cutters**

**> Internal vibrators and converters**

**> Rollers**



**Weber MASCHINENTECHNIK GmbH**

**Im Boden**

**57334 Bad Laasphe-Rückershausen**

**Telephone +49 (0) 27 54 / 398-0 – Fax +49 (0) 27 54 / 398-101**